

Supplied for Contract
DAAE-07-77-C-3218

SHOP MANUAL

THIokol MODEL 1200-C
(Serial Nos. 1682-1706)

GOVERNMENT PROCURING AGENCY:
U.S. ARMY TANK-AUTOMATIVE COMMAND
WARREN, MICHIGAN 48090

Supplied By

THIokol CORPORATION
LOGAN DIVISION
2503 NORTH MAIN STREET
LOGAN, UTAH 84321
phone: (801) 753-0226

VOLUME II

518-583-3190

Logan

TABLE OF CONTENTS
THIOLKOL MODEL 1200-C SHOP MANUAL

<u>SECTION</u>		<u>PAGE NO.</u>
	SPECIFICATIONS.....	a
1	ENGINE.....	1-1
	PART 1-1, LUBRICATION.....	1-1
	PART 1-2, OIL PAN REMOVAL & INSTALLATION- ENGINE IN VEHICLE.....	1-4
	PART 1-3, ENGINE REMOVAL AND INSTALLATION.....	1-5
2	FUEL SYSTEM.....	2-1
	PART 2-1, FUEL TANK ASSEMBLY.....	2-1
	PART 2-2, FUEL LINE.....	2-3
	PART 2-3, THROTTLE ASSEMBLY.....	2-9
	PART 2-4, CHOKE ASSEMBLY.....	2-14
3	EXHAUST SYSTEM.....	3-1
4	DRIVE SYSTEM.....	4-1
	PART 4-1, DRIVE SHAFT.....	4-1
	PART 4-2, JOURNAL & BEARING KITS.....	4-3
	PART 4-3, DRIVE UNIT ASSEMBLY.....	4-5
5	BRAKE ASSEMBLY.....	5-1
6	TRANSMISSION.....	6-1
	PART 6-1, LINKAGE.....	6-1
	PART 6-2, TRANSMISSION.....	6-4
7	TRACK ASSEMBLY.....	7-1
	PART 7-1, CLEAT REPLACEMENT.....	7-1
	PART 7-2, LACING REPLACEMENT.....	7-1
	PART 7-3, BELT REPLACEMENT.....	7-1
	PART 7-4, TRACK INSTALLATION & REMOVAL.....	7-1
8	SUSPENSION SYSTEM.....	8-1
	PART 8-1, WHEEL CHANGING PROCEDURES.....	8-1
	PART 8-2, AXLE REPLACEMENT PROCEDURES.....	8-2
	PART 8-3, TRACK ADJUSTMENT ASSEMBLY.....	8-8
9	COOLANT SYSTEM.....	9-1
	PART 9-1, RADIATOR.....	9-1
	PART 9-2, TRANSMISSION COOLER.....	9-2
	PART 9-3, HEATER.....	9-2
	PART 9-4, HEATER CONTROL.....	9-3
10	ELECTRICAL SYSTEM.....	10-1
	PART 10-1, INSTRUMENT PANEL.....	10-1

<u>SECTION</u>		<u>PAGE NO.</u>
11	SPEEDOMETER ASSEMBLY.....	11-1
12	CHASSIS & CAB.....	12-1
	PART 12-1, CHASSIS.....	12-1
	PART 12-2, CAB.....	12-3
13	TOOLS.....	13-1
14	LUBRICATION CHART.....	14-1
15	SPECIAL EQUIPMENT.....	15-1
	PART 15-1, WINTERIZATION KIT.....	15-1

SPECIFICATIONS - THIOKOL MODEL 1200-C

GENERAL: Thiokol Corporation's 1200-C Series off-highway vehicle is a track-laying type cargo and/or personnel carrier adapted for use over snow, marsh, muskeg and other marginal terrain.

MODEL

No. of passengers 4 to 6
Payload 1900 lbs.
Vehicle weight 6800 lbs.
Ground pressure at zero penetration:
 Empty 0.964 lbs./sq. in.
 Loaded 1.230 lbs./sq. in.
Total track area at zero penetration 7050 sq. in.

DIMENSIONS

Overall length 170"
Overall width 100"
Overall height 93"
Tread width 63½"
Ground clearance 11"
Cab inside length 70½"
Cab inside width 75½"
Cab inside height 44"

PERFORMANCE DATA

Climbing ability:
 Dirt to 70%
 Packed snow to 50%
 Soft snow to 35%
Sidehilling ability approx. 75% of climbability
Top speed 25 mph.
Turning radius 15 ft.
Fuel consumption 2 to 5 gal. per hour of operation

DRIVE TRAIN

Engine:
 Model Ford I-6 300 CID
 Gross horsepower 132 BHP at 3600 RPM
 Fuel gasoline, 91 RON
 Oil filter Fram PH-8A
 Air filter Ford, oil bath

Transmission Ford Model C-6, 3 speed
automatic, auxilliary
cooled, uses Ford type
F fluid
Drive unit Planetary controlled
differential in oil
bath, 6.14 to 1 axle
ratio

AXLES

Suspension Trailing arm type, load
rating 2400 ca lbs.
Tires Firestone tubeless, Urethane
filled, 6 ply, size 5:30/
4:50 12,

CAPACITIES

Fuel tank 44 gal.
Oil filter 1 qt.
Transmission 16 qts.
Drive unit 4 3/4 gal.
Engine cooling system 20 qts.
Engine oil 9 qts.

SECTION 1, ENGINE

PART 1-1, LUBRICATION

1. SEQUENCE:

1. drain engine
2. change oil filter
3. service air cleaner
4. replace drain plug & fill engine
5. check for leaks

2. ENGINE OIL:

See Fig. 1

The engine oil pan has been modified by a boxlike extension of its bottom called a deep sump. This sump is there to insure an adequate supply of oil on steep grades. The pan also has a heating unit and thermostat mounted on the passenger side.

Change the oil supplied with the engine after fifty hours of operation. After that, change oil after every one hundred hours of operation, or at shorter intervals when the vehicle is used at temperatures below 0° F.

SINGLE VISCOSITY OILS

MULTI-VISCOSITY OILS

<u>When Outside Temperature is Consistently</u>	<u>Use SAE Viscosity Number</u>	<u>When Outside Temperature is Consistently</u>	<u>Use SAE Viscosity Number</u>
-10° F to +32° F	(*) 10W	Below +32° F	(*) 5W-30
+10° F to +60° F	20W-20	-10° F to +90° F	10W-30
+32° F to +90° F	30	-10° F to +90° F (or above)	10W-40
Above 60° F	40	Above +10° F	20W-40

(*) Where sustained high RPM operation is anticipated, use 20W20

Below -20° F use DN 600 fluid.

To drain the oil from the engine, remove the plug located on the bottom of the deep sump on the pan. Access to the plug is through the hole in the oil pan guard located just under the oil pan on the front axle.

Access to the oil filler cap and tube is difficult in this vehicle, therefore pull out the PCV valve and, using a funnel, pour the oil in that opening.

The capacity of the engine oil system is 9 to 10 quarts, and it is a good idea to start checking the oil level after the ninth quart so you don't overfill. The dipstick is located between the fuel pump and the distributor.

REMINDER: DON'T FORGET TO REPLACE THE OIL PAN PLUG!

3. OIL FILTER:

See Fig. 1

This vehicle has a remote oil filter of the disposable cartridge type located on the driver's side on the back wall of the engine compartment.

The filter should be changed every time you change oil. You can sometimes remove the filter by hand but usually a strap wrench is needed. When installing a filter, give the rubber seal a light coat of oil then screw the filter on by hand until it seats, then tighten another half a turn. After the new filter is installed run the engine awhile and check for leaks.

Use a Fram PH-8A replacement filter.

4. AIR CLEANER:

See Fig. 1

The air cleaner on this vehicle is a heavy-duty oil bath type. It should be serviced every time the engine oil is changed, more often under severe dust conditions.

The air cleaner assembly must be removed for servicing. To remove it, take out the two bolts from the bracket on the driver's side; then unscrew the wing nut over on the passenger side. From the passenger side rotate the assembly until it will clear the hood and can be lifted from the carburetor. Remember not to tilt the assembly too much or you could spill oil.

The oil cup comes off by removing the wing nut located on the bottom of the cleaner assembly. Keep the cleaner assembly upright when removing the cup, otherwise the oil will spill.

To service, pour the oil from the cup, remove the accumulated sludge, and wipe clean. Then, using the same weight oil as is in the engine, fill the cup to the level stamped on the inside.

In addition to the above, every third or fourth time the oil is changed, the filter element should be cleaned in kerosene or Stoddard solvent.

Installation is the reverse of removal: Reassemble the cleaner assembly, place the assembly over the carburetor, rotate, then replace wing nut and bracket bolts.

5. NOTE:

Run engine every 30 - 45 days minimum. If engine has been setting over 45 days, crank the engine with coil wire off for 30 seconds to distribute the oil.

FIG. 1 ENGINE

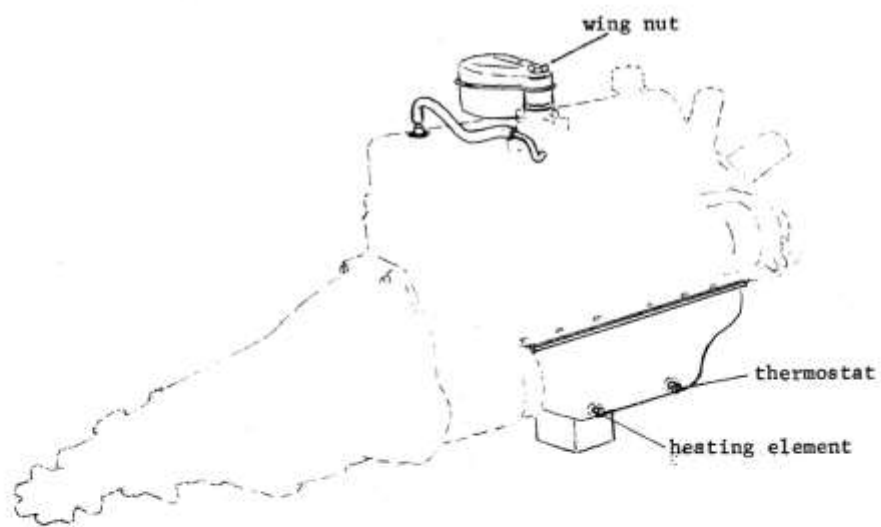
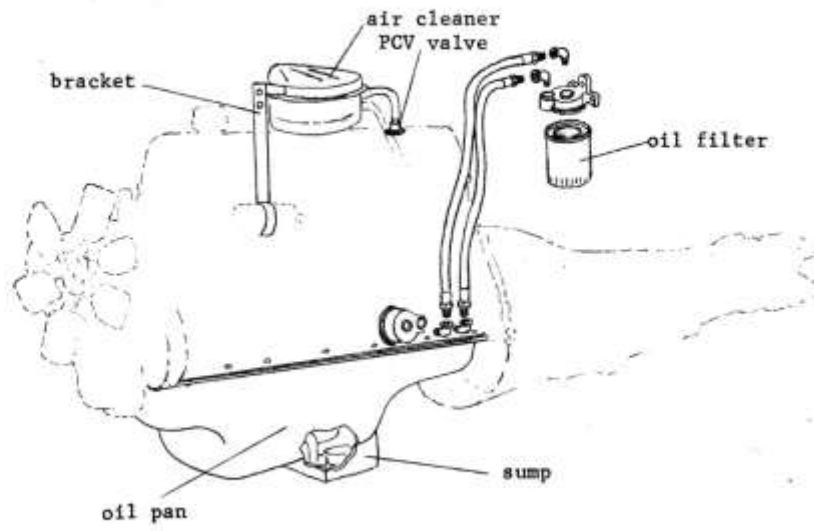

PART 1-2, OIL PAN REMOVAL & INSTALLATION - ENGINE IN VEHICLE

1. REMOVAL PROCEDURE:

- 1.2 Drain the engine oil as described in SECTION I, PART 1-1, item 3.
- 1.3 If the vehicle is tracked you must unlace the tracks and lift them away from the front; it isn't necessary to remove the tracks entirely. The procedure for unlacing the tracks is given in SECTION 7, PART 7-1.
- 1.4 Remove the front wheels as described in SECTION 8, PART 8-1, item 2.
- 1.5 Remove the front axle as described in SECTION 8, PART 8-2, item 2.
- 1.6 Remove the front cross-member:

Remove the bolts and rubber mounts which fasten the cross-member to the chassis and remove the bolts at each end of the cross-member.

Usually the cross-member fits tightly enough so that when the bolts and mounts are removed it will stay in place. If this is the case, simply tap one end of the cross-member down and out of the bracket, lower it to the ground, then tap the other end out. (See FIG. 2)

- 1.7 Unscrew the knurled retainer cups on the heating element and thermostat and disconnect the lead-in wires.
- 1.8 Remove the oil pan:

The oil pan is held to the block by twenty-five bolts; take these out and pry the pan off.

2. INSTALLATION PROCEDURE:

- 2.1 If a new pan is to be installed, install the heating element & thermostat and use a new pan gasket. (See SECTION 15)
- 2.2 On an old pan make sure you've replaced the drain plug and straighten pan if lip is locally deformed around bolt holes.
- 2.3 Stick a new gasket to the pan with a little grease or gasket sealer and place the assembly in position up to the crankcase. Then insert all of the bolts loosely. After all of the bolts are installed, tighten them with a torque of 10-12 ft./lbs.
- 2.4 Reverse the above removal procedure and replace the cross-member.

- 2.5 Replace the front axle assembly and wheels. Procedures are given in SECTION 8, PART 8-2, and SECTION 8, PART 8-1, respectively.
- 2.6 Relace the tracks and tighten as described in SECTION 7, PART 7-1.
- 2.7 Fill the engine with oil. The procedure is given in SECTION 1, PART 1-1

FIG. 2 CROSS MEMBER

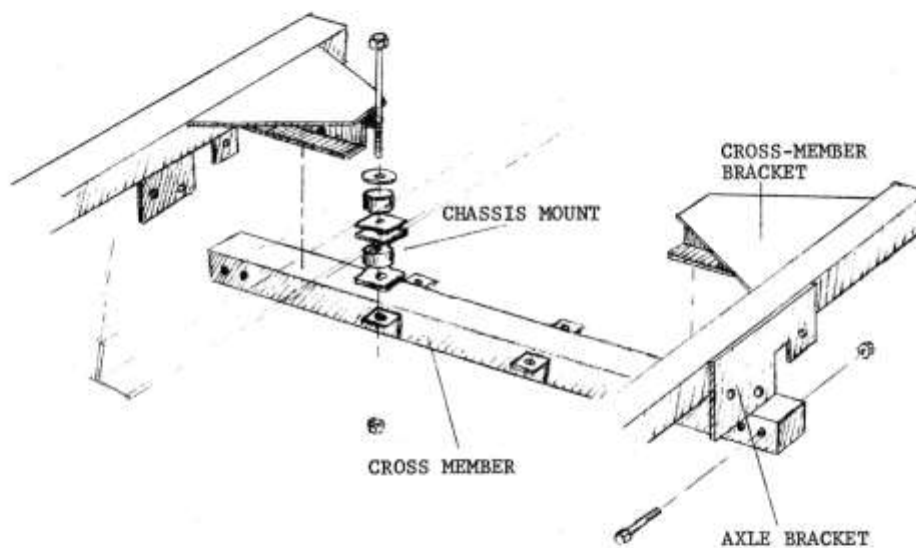

PART 1-3, ENGINE REMOVAL AND INSTALLATION:

1. REMOVAL PROCEDURE:

- 1.1 Remove instrument panel and cab (See SECTIONS 10 & 12)
- 1.2 Disconnect hoses at heater and remove heater assembly. (See SECTION 9, PART 9-3)
- 1.3 Remove radiator assembly. (See SECTION 9, PART 9-1) Be sure and plug hoses and transmission cooler. Also tie the hoses down to the engine somewhere so they won't get in the way when the engine is pulled out.

- 1.4 Remove the folding hood on the engine (See SECTION 12)
 - 1.5 Remove the cover plate on the lower chassis in the middle of the vehicle on the driver's side. Then disconnect the transmission control cable from the lever, and remove the "U" bolt holding the cable to the chassis just forward of the cover plate opening. (See SECTION 6)
 - 1.6 Disconnect the hand throttle cable at the engine, the choke cable at the carburetor, and the heater cable at the control valve on the heater hose. (See SECTIONS 2 & 9)
 - 1.7 Push the engine wiring harness plug down through the hole in the forward engine compartment cover, then remove the cover.
 - 1.8 Disconnect the engine wiring harness from the engine, taking care to mark the wires and their points of connection on the engine. Leave the harness connected to the terminal on the rear engine compartment housing, and pick the disconnected harness up out of the way.
 - 1.9 Disconnect the starter cable.
 - 1.10 Remove the header pipe section from the exhaust system. (See SECTION 3)
 - 1.11 Remove the pump, heater, and hoses comprising the engine winterization kit. (See SECTION 14)
 - 1.12 Disconnect ball joint at the point where foot pedal connects to throttle linkage. (See SECTION 2, PART 2-3)
 - 1.13 Disconnect the flexible fuel line at the inlet side of the fuel pump. (See SECTION 2, PART 2-2)
 - 1.14 Disconnect the brake cable from driveline disc brake assembly. (See SECTION 5)
 - 1.15 Disconnect remote oil filter hoses at the oil filter.
 - 1.16 Remove the bolts from the front motor mounts.
 - 1.17 Remove the drive shaft at the transmission flange yoke. (See SECTION 4)
 - 1.18 Remove the bolts holding rear mount crossmember located under the transmission to chassis.
 - 1.19 Using a suitable overhead crane or hoist pull the engine forward and out of the vehicle.
2. INSTALLATION PROCEDURE:
- Reverse the above removal procedure.

SECTION 2, FUEL SYSTEM

PART 2-1. FUEL TANK ASSEMBLY:

1. GENERAL:

See Fig. 3

Keeping the fuel tank filled will reduce the possibility of condensation forming in the tank or entering the fuel lines.

2. REMOVAL:

2.1 Unscrew 5 screws on tank sending unit, remove cap, then remove wires. Replace cap and screws.

2.2 Crawl underneath the vehicle and close the tank shut-off valve.

2.3 While still underneath, uncouple the fuel line.

2.4 Crawl out, reach up under the deck on either side of the tank and remove the nuts and washers from the threaded ends of the four hold-down straps. (threaded end of strap is toward rear of vehicle) Have someone hold the straps to prevent their twisting.

2.5 Bend the straps up and back so that the tank assembly can clear.

2.6 Lift the guard off.

2.7 Lift the tank up and out.

3. INSTALLATION:

3.1 Put the tank in place behind the cab with the shut-off valve through the central hole in the decking.

3.2 Place the guard on the tank.

3.3 Bend the straps down pushing the threaded ends through the holes in the decking.

3.4 Reach up under the decking on either side of the tank and install and tighten washers and nuts on the threaded ends of the straps. Have someone hold the straps to prevent their twisting.

- 3.5 Remove 5 screws and cap from sending unit, replace wires, then replace cap and screws.
- 3.6 Crawl underneath the vehicle and couple the fuel line.
- 3.7 While still underneath open the tank shut-off valve and check for leaks.

FIG 3 - FUEL TANK ASSEMBLY

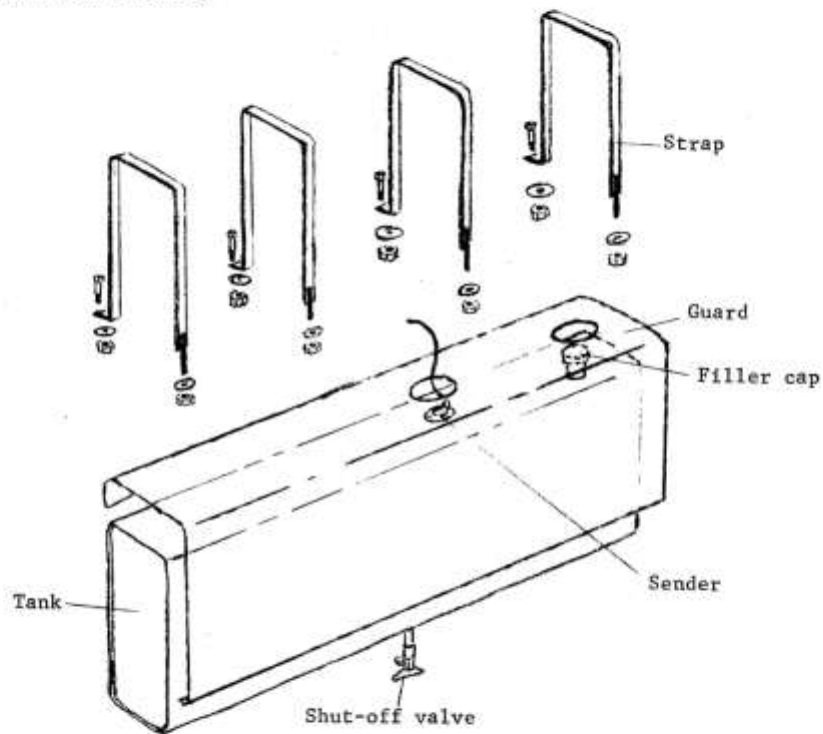

PART 2-2, FUEL LINE:

1. FUEL TANK TO SEDIMENT BOWL:

1.1 General:

The line from the fuel tank to the sediment bowl assembly is 5/16" steel tubing. The line is flared at the tank coupling but not at the bowl assembly connection; the bowl assembly requires a compression sleeve connection.

The line is also connected to the chassis by four line clamps.

1.2 To clear the line:

1.2.1 Crawl underneath the vehicle, close the fuel tank shut-off valve, and uncouple the line at the tank.

1.2.2 Remove the sediment bowl as described in item 2 below and blow compressed air back through inlet.

1.3 Removal:

1.3.1 Crawl underneath the vehicle, close the fuel tank shut-off valve, and uncouple the line at the tank.

1.3.2 Uncouple the line at the sediment bowl and, following the line back to the tank, remove the four line clamps.

1.4 Installation:

Reverse the above removal procedure.

1.5 Replacement:

1.5.1 Remove the old line as indicated above. (item 1.3)

1.5.2 Cut the new line to length and square the ends with a file.

1.5.3 Ream the inside edge of one end and bevel the outside edge of the other end. (The bevel is to make the compression sleeve easier to slip on when making the sediment bowl connection.) Remove any metal chips from inside the tube and flare the reamed end.

1.5.4 Place an inverted flare nut over the new line and up to the flared end. Bend the new line to the correct configuration.

- 1.5.5 Crawl underneath the vehicle and place the new line up to the chassis with the flared end and nut toward the fuel tank. Install the four line clamps and connect the flared end to the tank.
- 1.5.6 To connect the other end of the line to the sediment bowl, slip an inverted flare nut over the end then put on a compression sleeve. Insert the tubing and sleeve into the sediment bowl assembly inlet as far as possible, then screw down the flare nut.
- 1.5.7 Open the tank shut-off valve.

2. SEDIMENT BOWL ASSEMBLY:

See Fig. 4

2.1 General:

The sediment bowl should be serviced periodically as well as the wire mesh filter inside the bowl housing. If the wire mesh is clogged or the bowl too full of sediment, the fuel flow will be impaired.

2.2 Servicing:

- 2.2.1 Crawl underneath the vehicle and close the fuel tank shut-off valve.
- 2.2.2 Still underneath the vehicle, unscrew the knurled nut at the bottom of the bowl, swing the wire bracket out of the way, remove the bowl and clean out the sediment.
- 2.2.3 The wire mesh filter is held in the housing by the rubber gasket. To remove the filter, remove the gasket and the filter will either drop out or can be pried out with a fingernail. The filter can be cleaned with a toothbrush or compressed air.
- 2.2.4 Put the filter in place in the housing and replace the rubber gasket. Place the bowl up to the gasket, position the wire bracket and tighten the knurled screw.
- 2.2.5 Open the tank shut-off valve.

2.3 Removal:

- 2.3.1 Crawl underneath the vehicle and close the fuel tank shut-off valve.
- 2.3.2 Still underneath the vehicle, unscrew the inverted flare nut and pull the fuel line, nut, and sleeve from the inlet.

2.3.3 Loosen the hose clamp on the outlet side of the electromagnetic shut-off, slide the clamp up toward the fuel pump and pull the hose off. Then, applying a wrench to the adapter fitting, unscrew the adapter fitting, shut-off valve, and hose connector as a unit.

2.3.4 Remove the mounting screws, nuts, and washers from the assembly and remove the assembly from the chassis.

2.4 Installation:

Reverse the above removal procedure.

3. ELECTROMAGNETIC SHUT-OFF VALVE:

See Fig. 4

3.1 General:

The electromagnetic shut-off valve is basically a nonserviceable item; if it becomes non-functional it must be replaced. Nonfunction usually consists of the valve jamming in an open or shut position. It is occasionally possible to remove dirt or contamination jamming the valve by removing it, connecting it to a 12V DC source, and back blowing with an air hose.

3.2 Testing for function:

3.2.1 With the engine off listen as the key is turned from "off" to "on". The valve, if operational, will make an audible "click" as it shuts on and off.

3.2.2 Malfunction could also be caused by a break in the leads or disconnected leads. To test for this, connect the valve terminals to a DC 12V source and listen for a "click" as the valve shuts on or off.

3.2.3 Another way to test the function of the valve is as follows: With the engine off and the ignition key in the "off" position, loosen the hose clamp on the outlet side of the valve and slide the clamp up the hose toward the pump and pull the hose off. No fuel should flow out. Now turn the ignition key to the "on" position. This should open the valve and let fuel flow out.

3.3 Removal:

3.3.1 Loosen the hose clamp on the outlet side of the shut-off valve, slide the clamp up the hose toward the pump, and pull the hose off.

3.3.2 Place a wrench over the nut on the outlet end of the valve and a wrench on the hose connector nut, then screw the connector out of the valve.

3.3.3 Now place a wrench over the nut on the inlet side of the valve and a wrench over the adapter, then screw the valve off.

3.4 Installation:

Reverse the above removal procedure.

4. FUEL FILTER:

See Fig. 4

4.1 General:

The disposable filter is located on top of the fuel pump body and should be replaced every 200 hours of operation.

4.2 Removal:

Unscrew the filter housing and discard the filter and gasket.

4.3 Replacement:

4.3.1 Place the new filter element over the spout in the pump body.

4.3.2 Coat the new gasket with engine oil and fit it into the housing. Install and tighten the housing until the gasket seats, then tighten an additional 1/8 turn.

5. PUMP TO CARBURETOR:

5.1 General:

The fuel line from the fuel pump to the carburetor is 5/16" steel tubing.

5.2 Removal:

Unscrew flare nuts at the fuel pump and the carburetor.

5.3 Installation:

Screw in and tighten flare nuts at fuel pump and carburetor.

5.4 Replacement:

5.4.1 Remove the old line as indicated above.

- 5.4.2 Cut the new line to length and square the ends with a file.
- 5.4.3 Ream the inside edges of both ends and remove any metal chips.
- 5.4.4 Place the inverted flare nuts in their proper positions over the line, then flare both ends. Bend new line to correct configuration.
- 5.4.5 Install as above.

FIG. 4 FUEL LINE

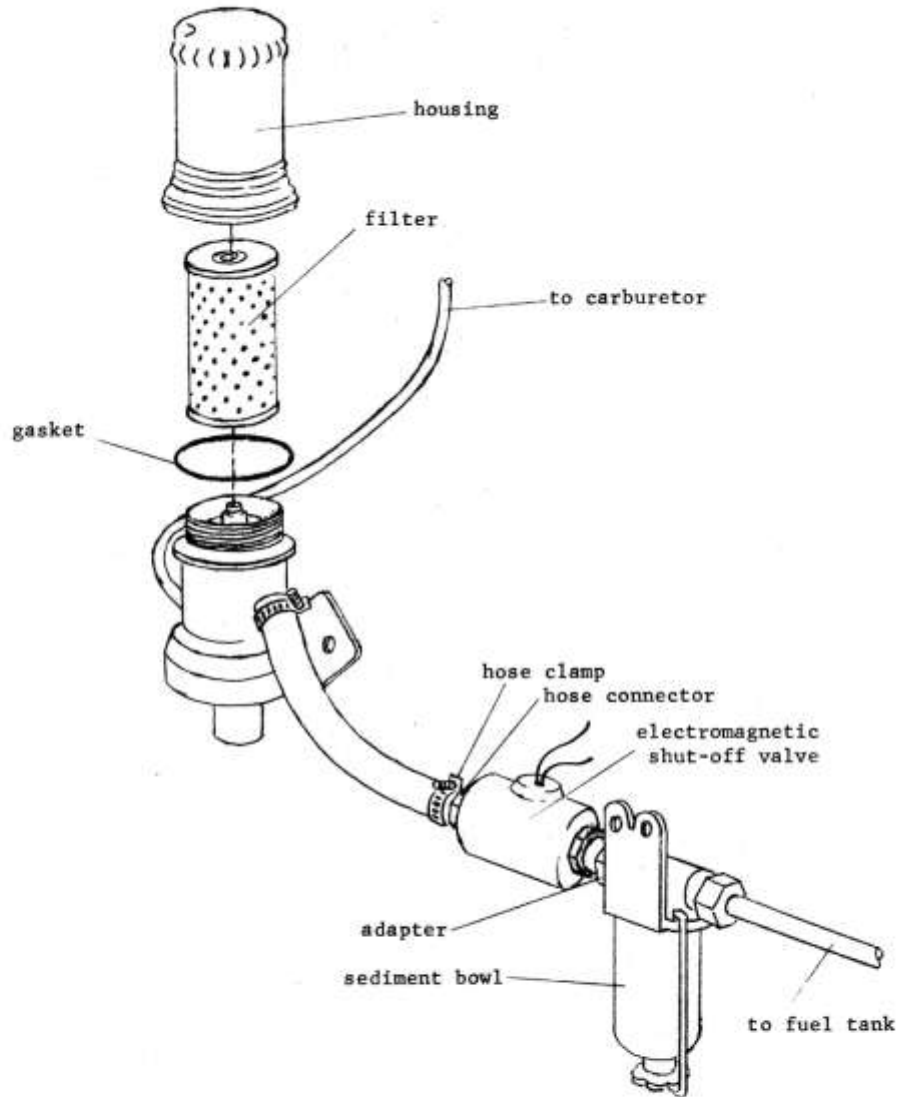

PART 2-3, THROTTLE ASSEMBLY:

1. FOOT THROTTLE LINKAGE:

1.1 Operation:

See Fig. 5

As the accelerator pedal (1) is depressed, throttle rod (6) is pulled forward and pivots the crank assembly (17). The crank assembly, being in contact with the compression spring (19), pushes throttle rod (25) back.

As throttle rod (25) is pushed back the crank (28) pivots around the crank bracket (22) and pushes up the throttle link (30). The throttle link then pivots the carburetor throttle lever (33).

As the pedal is further depressed and the throttle rods are moved still more, the carburetor throttle lever becomes fully engaged and will pivot no further. The compression spring (19) then, under pressure from the still advancing throttle rod, compresses and allows further travel of throttle rod (6) and the crank assembly (17). This lets the crank assembly finally contact compression spring (12) thus pushing down the kickdown rod (14) and activating the kickdown lever (13) on the transmission.

Further pedal travel is prevented by the adjustable stop (4).

1.2 Maintenance:

Periodically grease the crank assembly (17) with all temperature grease conforming to MIL-G-10924-A or Conoco DN-600 grease.

1.3 Adjustment:

See Fig. 5

1.3.1 Screw in retaining nut (20) until compression spring (19) contacts guide (21) and depressing the pedal (1) produces an immediate reaction on the carburetor throttle lever (33).

1.3.2 Next, set the collar & set screw (15) on the kickdown rod (14) so that when the pedal is depressed to the point where the carburetor throttle is fully engaged, guide (11) is just contacting compression spring (12) and further movement of the pedal will begin to push down the kickdown rod.

1.3.3 Now set the adjustable stop (4) under the accelerator pedal so that there is just a little more than enough pedal travel to complete the movement of the kickdown rod (14) and the kickdown lever (13).

FIG 5-THROTTLE ASSEMBLY

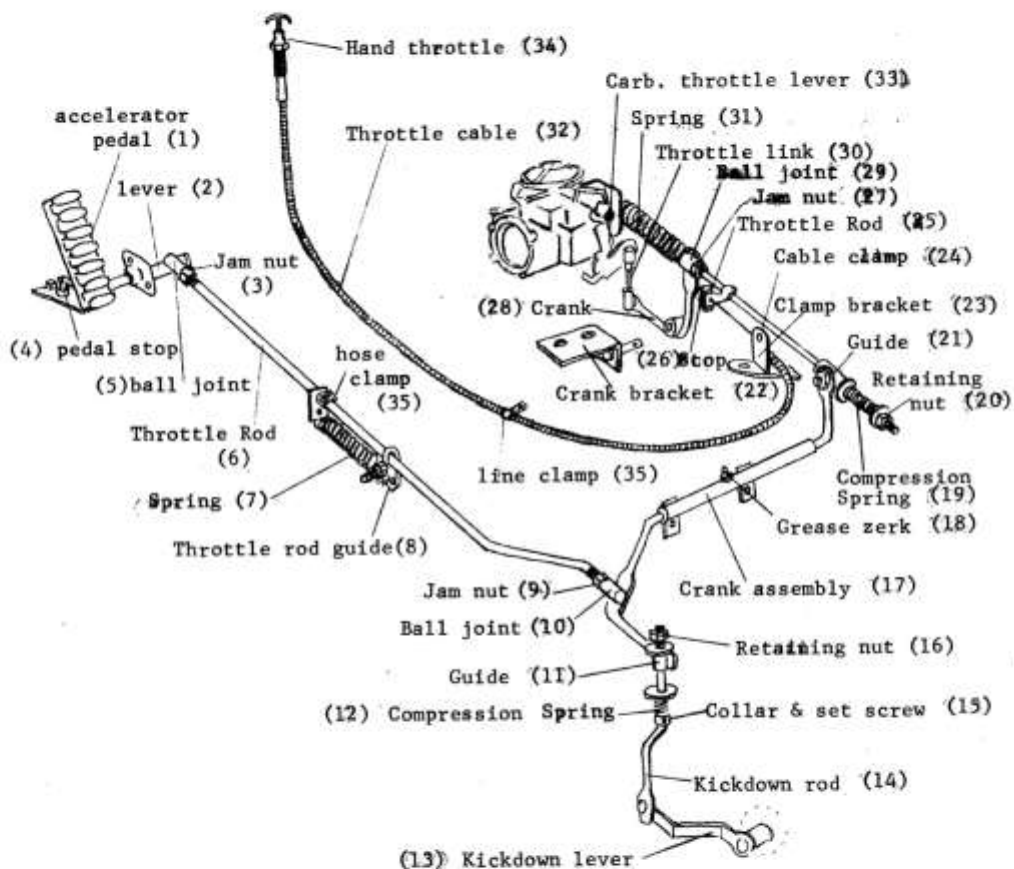

1.4 Accelerator pedal angle:

The pedal angle is adjusted by changing the length of the throttle rod (6). This is done by loosening the jam nuts and screwing the ball joints in or out; the shorter the rod, the more upright the pedal becomes, and vice versa. Remember to tighten down the jam nuts when the adjustment has been made.

2. HAND THROTTLE:

2.1 Operation:

See Fig. 5

The hand throttle does essentially the same thing as the foot throttle, except that it does not engage the kickdown lever.

Pulling up on the "T" handle causes the cable to pull throttle rod (25) back, which, as in the above foot throttle explanation, activates the carburetor throttle lever.

Twisting the "T" handle locks it in any desired position.

2.2 Removal:

See Fig. 5

2.2.1 Loosen and remove the cable stop in front of the tab on throttle rod (25) and remove the cable from the cable clamp (24).

2.2.2 Pull the "T" handle up so that the inner cable pulls out of the tab on throttle rod (25).

2.2.3 Remove the line clamp (35) on the driver's side.

2.2.4 Reach up under the engine housing by the transmission shift lever and unscrew the jam nut on the "T" handle housing.

2.2.5 Pull the "T" handle assembly and cable out.

2.3 Reinstallation:

See Fig. 5

2.3.1 Push the cable & "T" handle assembly through the hole in the engine housing next to the transmission shift lever.

2.3.2 Thread the washer and jam nut over the end of the cable and up to the "T" handle housing under the engine housing. Tighten down the jam nut.

- 2.3.3 Thread the inner cable through the hole in the tab on throttle rod (25) and install the stop.
- 2.3.4 Taking care not to pull on the cable enough to affect the throttle lever position, place outer cable up to the bracket (22) and secure it with the cable clamp (24).
- 2.3.5 Replace the line clamp (35) on driver's side.

2.4 Replacement:

See Fig. 5

- 2.4.1 Install the "T" handle assembly as in the installation procedure above.
- 2.4.2 Pull the "T" handle up in its housing a distance equal to that from the cable clamp (24) to the tab on throttle rod (25) plus three quarters of an inch. Make sure that the throttle rod is all the way forward with carburetor throttle lever closed when measurement is taken.
- 2.4.3 Install the outer cable in a gentle curve around the back of the engine up to the clamp bracket (23) and into the cable clamp (24). Tighten the cable clamp and install the line clamp (35) on the driver's side of the engine.
- 2.4.4 Cut off the cable leaving about 1/4" of cable extending past the clamp (24) toward the carburetor.
- 2.4.5 Push the "T" handle down into its housing all the way. This will push the inner cable out of the severed end at the clamp. Guide the inner cable through the hole in the tab on throttle rod (25).
- 2.4.6 Install the stop (26) on the cable on the carburetor side of the tab and right up to the tab; tighten. Take a pair of pliers and bend up the inner cable extending past the stop.

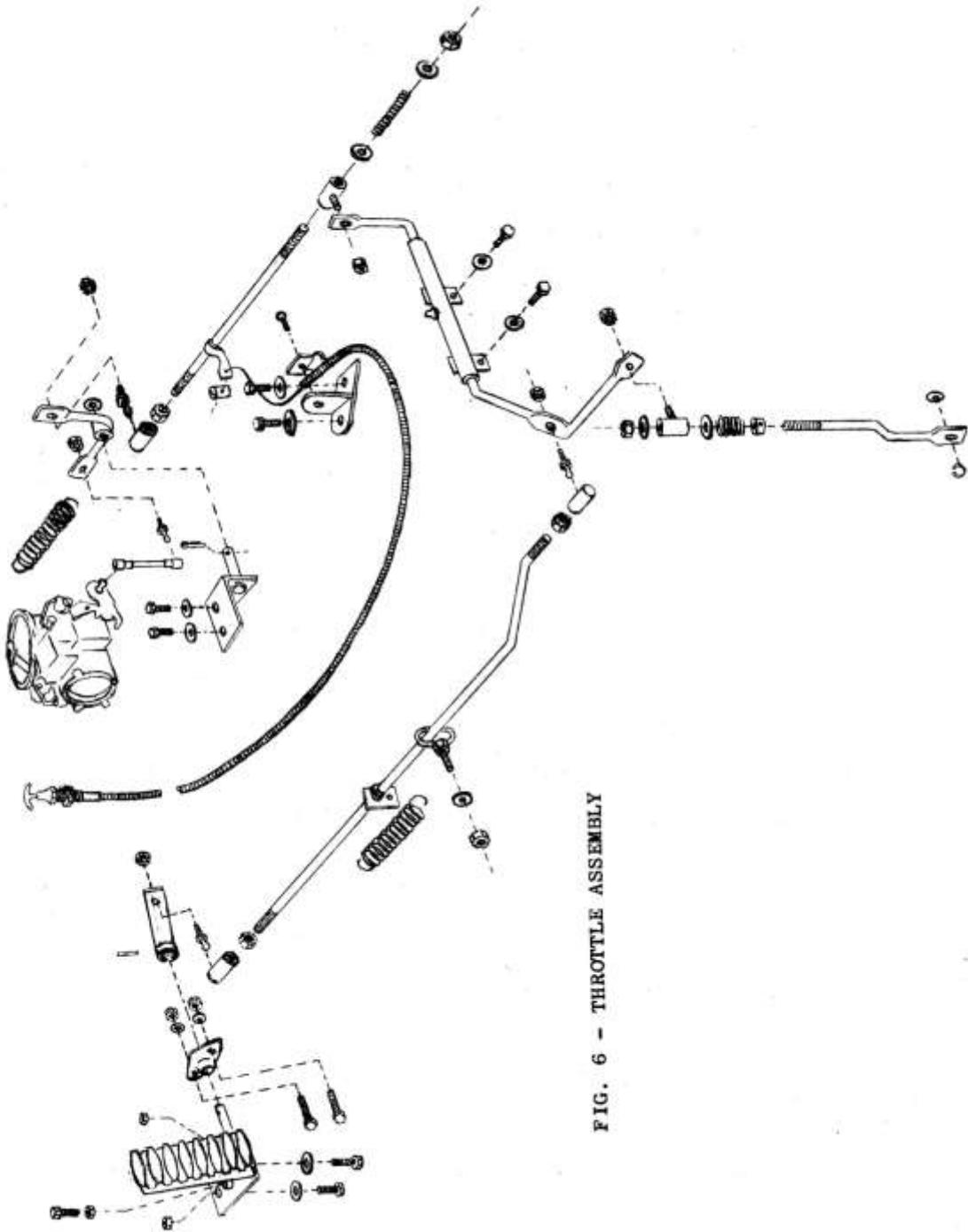

FIG. 6 - THROTTLE ASSEMBLY

PART 2-4, CHOKE ASSEMBLY:

1. OPERATION:

See Fig. 7

Pulling up on the choke knob in the cab causes the cable to pull on and rotate the choke lever which activates the butterfly valve in the carburetor. Choke knob is black knob next to "T" handle.

2. REMOVAL:

See Fig. 7

- 2.1 Loosen the set screw on the choke lever cable stop and then remove the outer cable from the cable clamp.
- 2.2 Pull up on the choke knob enough to pull the inner cable out of the stop.
- 2.3 Reach up under the engine housing by the heater control and unscrew the jam nut on the choke knob housing.
- 2.4 Pull the choke knob assembly and cable out through the hole in the engine housing.

3. REINSTALLATION:

See Fig. 7

- 3.1 Push the cable and choke knob assembly, minus the washer and jam nut, through the hole in the engine housing next to the heater control.
- 3.2 Thread the washer and jam nut over the end of the cable and up to the choke knob housing under the engine housing. Tighten down the jam nut.
- 3.3 With the butterfly full open, push the inner cable through the hole in the stop on the choke lever and tighten the set screw.
- 3.4 Taking care not to move the butterfly from its open position, secure the outer cable (sheath) in the cable clamp.

4. REPLACEMENT:

See Fig. 7

- 4.1 Install the choke knob assembly as described above.
- 4.2 Pull the choke knob up a distance equal to that from the cable clamp to the stop on the choke lever plus about 3/4". Make sure that the choke lever is rotated all the way back with the butterfly fully opened when measurement is taken.

- 4.3 Take the outer cable (sheath) down to the cable clamp without any excess slack, insert the cable into the clamp and then tighten.
- 4.4 Cut the cable, leaving about 1/4" extending past the clamp toward the choke lever.
- 4.5 Push the choke knob down all the way. This will push the inner cable out of the severed end at the cable clamp. Guide the inner cable through the hole in the stop on the choke lever.
- 4.6 Tighten the set screw on the stop and take a pair of pliers and bend up the inner cable extending past the stop.

FIG. 7 CHOKE ASSEMBLY

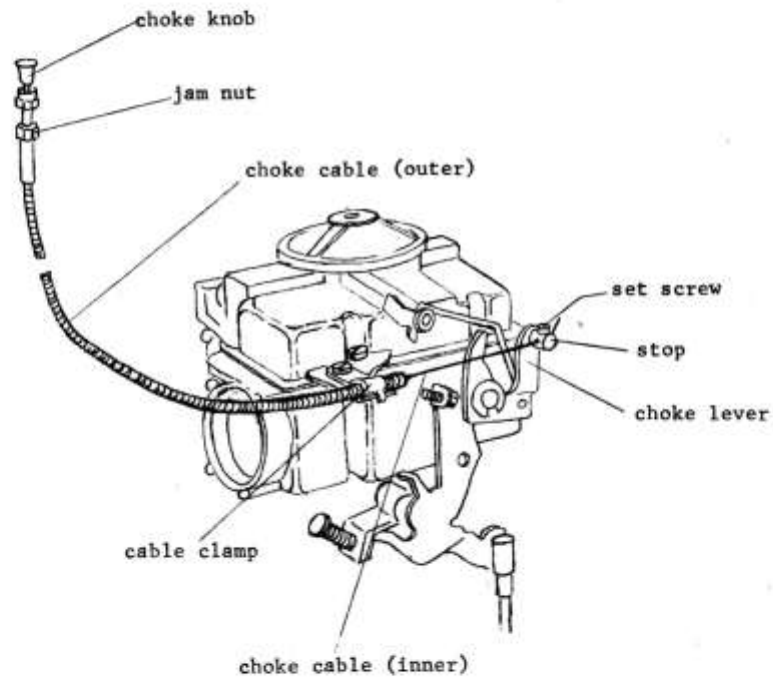

1
2
3
4
5
6
7
8
9
10
11
12
13
14
15
16
17
18
19
20
21
22
23
24
25
26
27
28
29
30
31
32
33
34
35
36
37
38
39
40
41
42
43
44
45
46
47
48
49
50
51
52
53
54
55
56
57
58
59
60
61
62
63
64
65
66
67
68
69
70
71
72
73
74
75
76
77
78
79
80
81
82
83
84
85
86
87
88
89
90
91
92
93
94
95
96
97
98
99
100

SECTION 3, EXHAUST SYSTEM

1. REMOVAL AND INSTALLATION OF EXHAUST SYSTEM COMPONENTS:

1.1 ACCESS:

Except for three points, access to the exhaust system is from underneath the vehicle:

1.1.1 The standard exhaust clamp on the rear-"S" section-to-tail-pipe joint is reached by removing the grating over the differential.

1.1.2 The modified clamp on the tail pipe is hung from a tab welded to the outside face of the rear decking support over the differential.

1.1.3 The header clamp is reached through the engine compartment hood on the passenger side.

1.2 GENERAL REMOVAL PROCEDURE:

Remove the clamps from both end of the section to be replaced. Also remove any modified clamps to the rear of that section so the rear components will be free to move back and forward.

Note: Removal of a modified clamp means removing only the "U" bolt. The upper part of the clamp is not removed from the chassis but is swung up and out of the way.

Separate the section's forward joint first, pulling that section and all the rear components back as a unit. Then separate the section's rear joint and pull it forward and out of the rear component unit. This procedure is made much easier if the joint to be separated is first heated to a red heat and the section to be removed is rocked from side to side. This will enlarge and loosen the joint.

WARNING: SOME PARTS OF THE EXHAUST SYSTEM ARE CLOSE TO THE FUEL LINE, BE CAREFUL THAT YOU DO NOT HEAT FUEL LINES OR START A FIRE WHEN HEATING THE JOINTS.

To install a section, drive the new section onto the section in front of it (front means front of vehicle). Hold the old section to prevent damage to it or the exhaust manifold. Then drive the rear components, as a unit, onto the new section. When the new section is lined up and fitted correctly, install and tighten the clamps.

1.3 PROCEDURE FOR REMOVAL AND INSTALLATION OF HEADER:

Removal and installation of the header presents special problems; Therefore a specific procedure is given here.

1.3.1 Removal:

- 1.3.1.1 Remove the crank assembly from the throttle linkage. Loosen the stop and remove the hand throttle cable from the tab on the passenger side throttle rod, then move this rod as far as possible toward the driver's side.
SEE FIGS. 5 & 6, SECTION 2
- 1.3.1.2 Remove the nuts and washers from the header clamp.
- 1.3.1.3 Remove the hanger bolt from the modified clamp on the tailpipe.
- 1.3.1.4 Crawl underneath the vehicle and remove the "U" bolts from the two remaining modified clamps. Swing the upper parts of the clamps out of the way.
- 1.3.1.5 Pull the header out of the manifold, pushing the entire exhaust system back.
- 1.3.1.6 Heat and loosen the header-front-"S"-section joint and pull the header from the front "S" section.
- 1.3.1.7 While still underneath the vehicle pull the header out of the engine compartment. To do this, pick the header flange and clamp up high and go over and to the side of the transmission dipstick.

1.3.2 Installation:

- 1.3.2.1 From underneath the vehicle, insert the header into the engine compartment. As in the removal procedure above, the clamp and flange must go over and to one side of the transmission dipstick.
- 1.3.2.2 Install the header clamp from above
- 1.3.2.3 Reassemble the throttle linkage
SEE FIGS. 5 & 6, SECTION 2

- 1.3.2.4 Underneath the vehicle again, drive the front "S" section, along with the muffler, rear "S" section, and tail pipe, over the header.
- 1.3.2.5 Install the "U" bolts to the modified clamps at their respective joints.
- 1.3.2.6 Replace the hanger bolt in the modified clamp on the tail pipe.

1.4 MUFFLER REMOVAL & INSTALLATION:

1.4.1 Removal:

- 1.4.1.1 Remove as any other section, except the drive shaft has to be unhooked from the drive unit and moved over to allow the muffler to pass. See Section 4.
- 1.4.1.2 The muffler should be installed with the dump port down and with the strap clamped around it covering the port.
- 1.4.1.3 No more than two inches of pipe should extend into either end of the muffler.

1.5 EXHAUST SYSTEM MAINTENANCE:

- 1.5.1 Replace sections as needed.
- 1.5.2 Check periodically for leaks in the system and loose joints.
- 1.5.3 The spark arrestor muffler on this vehicle is equipped with a dump port to get rid of the carbon and scale it collects as a result of its spark arresting function. The stainless steel strap keeps the port closed when it is not in use.

The accumulated carbon and scale is dumped by loosening the strap when the engine is cool and running the engine for a few minutes. Be sure you do this in a safe location and that you retighten strap after the operation is finished.

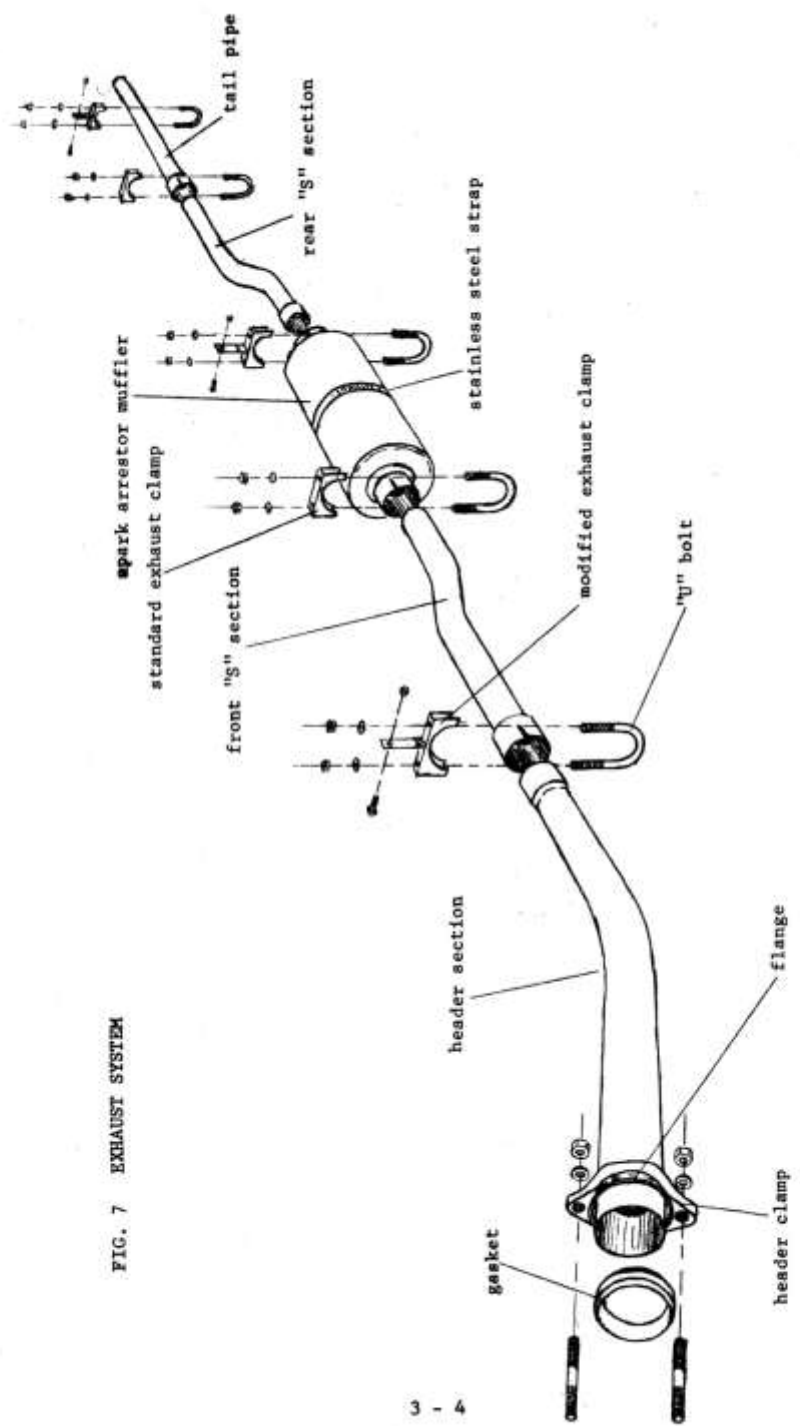

FIG. 7 EXHAUST SYSTEM

SECTION 4, DRIVE SYSTEM

PART 4-1, DRIVE SHAFT:

1. REMOVAL:

See Fig. 8

- 1.1 Crawl underneath the vehicle up to the flange yoke on the transmission and remove the four capscrews and washers and the two retainers that hold the journal and bearing kit to the flange yoke.
- 1.2 Supporting the drive shaft, pull it and the journal and bearing kit out of the flange yoke and lower that end of the shaft to the ground. Don't let the bearings slide off the journals as the shaft comes free.
- 1.3 Remove the four nuts and washers and the two "U" bolts from the end yoke.
- 1.4 Then, supporting the shaft, pull it and the journal and bearing kit out of the end yoke. Again, don't let the bearings slide off the journals as the shaft comes free.

NOTE:

Alternately, if you don't need or wish to separate the journal and bearing kit from the flange yoke on the differential when removing the driveshaft proceed as follows:

1. Remove the four nuts and washers and the two "U" bolts from the end yoke, then, supporting the shaft, pull it and the journal and bearing kit out of the end yoke.
2. Being careful not to let the bearings slide off the journals, lower that end to the ground.
3. Now, unscrew the knurled dust cap to the rear of the flange yoke and the splined section of the driveshaft will slide out of the sleeve yoke.

2. INSTALLATION:

See Fig. 8

Reverse the above removal procedure. -Be sure that sleeve yoke and weld yoke are parallel.

3. MAINTENANCE:

Grease the journal & bearing kits and sleeve yoke every 50 hours of operation with all temperature grease conforming to MIL-G-10924A or Conoco DN-600 grease.

FIG. 8 DRIVE SHAFT ASSEMBLY

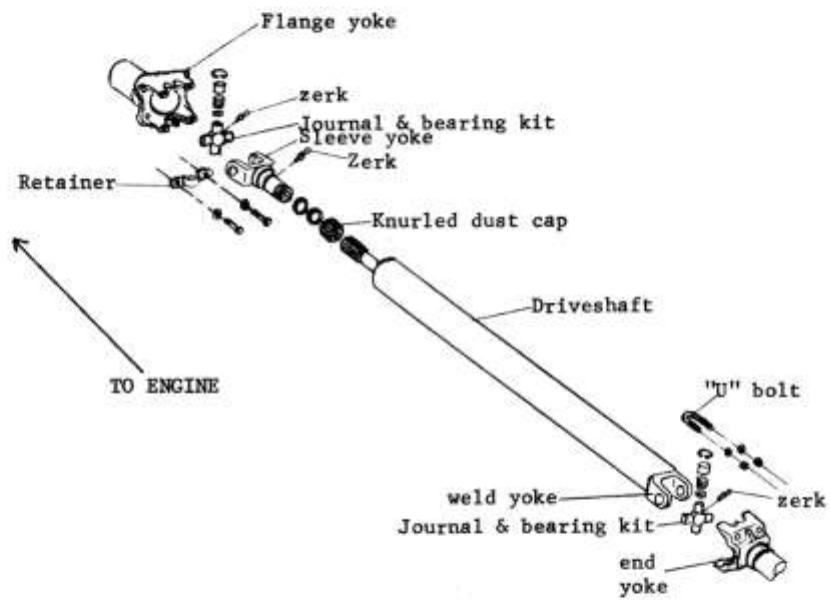

PART 4-2, JOURNAL & BEARING KITS:

1. REMOVAL OF A KIT:

See Fig. 8

- 1.1 Remove the drive shaft as described in PART 4-1, Items I. A. & I. B.
- 1.2 Remove the bearings from the free journals.
- 1.3 Remove the grease zerk.
- 1.4 Remove the retaining rings from the yoke.
- 1.5 Using a press and a plug slightly smaller than the hole in the yoke, or using a soft drift and a hammer and supporting the yoke in a bench vise, press or drive on the surface of one bearing and push the other bearing out the other side of the yoke. Pull the bearing off the journal.
- 1.6 Turn the yoke over and drive or press out the other bearing.
- 1.7 Take the journal assembly out of the yoke.

2. INSTALLATION OF A KIT:

See Fig. 8

- 2.1 Remove the grease zerk and two opposing bearings.
- 2.2 Insert the journals-minus-bearings into the yoke.
- 2.3 Holding the journal and bearing kit inside the yoke and over to one side so that one journal extends beyond the outside face of the yoke, start a bearing on that journal.
- 2.4 Then, using a press or a bench vise and a plug slightly smaller than the hole in the yoke, drive the bearing on into the yoke and over the journal. Keep driving until the bearing is seated and the other journal is pushed flush with the outside face of the other side of the yoke.
- 2.5 Turn the yoke over and start a bearing on the opposite journal and proceed as described in step "D" above.
- 2.6 When both bearings are seated and one bearing is pushed flush with an outside face of the yoke, the top of the other bearing will be below the other outside face on the yoke, leaving a space. Install the first retaining ring in that space.
- 2.7 Turn the yoke over and drive the bearings back until stopped by the retaining ring.

2.8 Now install the second retaining ring.

2.9 Install the grease zerk and grease the now installed journal and bearing kit.

PART 4-3, DRIVE UNIT ASSEMBLY:

1. GENERAL:

The steering differential is a planetary controlled differential which provides directional and braking control for the vehicle. There are two steering drums within the differential. The right drum controls the rotation of the right rear axle and the left drum controls the rotation of the left rear axle. This control is achieved by actuating the hydraulically-controlled steering brake bands on either or both drums.

When the vehicle operator pulls the right-hand steering lever to make a right turn, the right steering brake band tightens around the right steering drum. With the right drum stationary, speed in the right track drops by one-third. Speed in the left track simultaneously increases by one-third and the left track powers the vehicle into a right turn. When the vehicle operator pulls both steering levers simultaneously, the brake bands tighten over both drums and the vehicle is stopped in the same manner as with conventional hydraulic brakes.

The differential unit itself utilizes six external and six internal pinions, as well as two compensating gears, to allow independent rotation of either steering drum while the other drum is slowed or stopped during a turn.

2. SPECIAL TOOLS:

Major repairs to the unit necessitates a well-equipped shop which includes and overhead crane or some form of heavy lifting equipment and access to a height gauge and surface plate. Thiokol offers a tool kit which includes specially designed tools for servicing items peculiar to the steering differential. These tools provide the mechanic with almost everything necessary--over and above the standard tools in the mechanic's inventory--to completely disassemble the steering differential, check or correct critical specifications, make needed repairs and reassemble the unit in the shortest possible time.

<u>TOOL</u>	<u>PART NO.</u>	<u>FUNCTION</u>
Torque wrench	2130040	Bolt torque values in unit range from 12-140 ft. lbs.
Dial indicator	2130039	Measure backlash, and steering drum runout.
Lifting sling	2130038	For lowering drive unit assembly into case and lifting assembly out of case when double chain sling does not have proper clearance.

<u>TOOL</u>	<u>PART NO.</u>	<u>FUNCTION</u>
Double chain sling	2130037	For lifting drive unit assembly. NOTE: THIS SLING SHOULD BE USED FOR ALL LIFTING OF DRIVE UNIT ASSEMBLY OTHER THAN THE ACTUAL LOWERING OF THE UNIT INTO THE CASE.
Spanner wrench	2130036	For removing drive unit bearing lock nuts when unit is out of case.
Puller	2130035	For bearing and external pinion removal.
Nut wrench tool (4)	2130034	Used in place of unitorque nuts when shim pack and backlash are being determined.
Nut and washer holder	210033	Used to start nuts on bolts within the drive unit case where there is too little clearance to position nuts by hand.
Lifting beam	2130030	Used to support drive unit while it is in case, particularly when shim width is being determined.
Bearing puller plug	2130029	Used with puller to remove drive unit assembly bearings.
Gasket and shim alignment tool	2130028	Used for quick alignment of gaskets and shims with bolt holes.
Steering band securing hooks	2130027	Used to hold steering bands in place on drums.
Bearing driver	2130026	Used for installing drive unit assembly bearings.

3. ALTERNATIVES TO THIOKOL TOOLS:

The list below offers alternatives to the specialized Thiokol tools mentioned in Item 2 above.

Tools for which there are no ready substitutes are: a torque wrench with a range of 12-140 ft. lbs., a dial indicator, and an adjustable puller.

THIOKOL TOOL

Lifting sling

Double chain sling

Nut wrench tool (4)

Nut and washer holder

Bearing driver

Spanner wrench

Lifting beam

Bearing puller plug

Steering band
securing hooks (2)

Gasket and shim
alignment tool

Bearing nut removal tool
(internal spanner)

ALTERNATIVE TOOL

Any lifting sling capable of supporting 200 pounds which can be wrapped around the center of the drive unit assembly so the unit can be tilted as it is being lowered into the case.

Any chain sling with two hooks capable of supporting up to 1/2 ton.

These tools are simply 5/8-11 NC nuts welded onto 12-inch metal handles. The tools save time and bolt/nut wear when determining shim pack width and backlash.

A magnet on a handle can be substituted

A piece of pipe approx. 2 3/4" in diameter and 6" long.

Any 2" to 4 3/4" adjustable spanner.

A 2 x 4 with two holes drilled in it at the points which would intersect the outside edges of the steering drums. Install two hooks through the holes with threaded shafts so that the drive unit assembly height in the case can be adjusted by loosening or tightening the nuts on the hooks.

Any plate or block approx. 2" in diameter which can be held in place against the drive unit assembly main bearing shaft and not interfere with bearing removal.

Coat-hanger wire or any flexible wire of similar gauge.

Any straight, rigid rod of smaller diameter than the bolt hole.

A chisel or punch. NOTE: THESE TOOLS WILL NOT BE NEARLY AS EFFECTIVE AS THE SPECIAL THIOKOL TOOL AND GREAT CARE MUST BE EXERCISED NOT TO DAMAGE THE DRIVE UNIT CASE WHEN THESE TOOLS ARE USED.

4. REMOVAL OF DRIVE UNIT ASSEMBLY:

See Fig. 9

- 4.1 Remove both tracks as described in SECTION 7, PART 7-1.
- 4.2 Disconnect the wires from: (1) the temperature sending unit located at the bottom front of the drive unit, (2) the thermostat located in the middle rear of the drive unit case, and (3) the heating unit located at the bottom rear of the drive unit case.
- 4.3 Remove the heating element located at the bottom rear of the drive unit case and let the oil drain from the case. When the oil has completely drained, clean and replace the heating element.
- 4.4 Remove the grid plate over drive unit assembly.
- 4.5 Disconnect the hydraulic slave cylinders from the drive unit case lid. Mark the cylinders to indicate proper position for reinstallation.
- 4.6 Remove the 4 bolts, washers, and nuts from the 4 rubber mounts assemblies. These bolts run through the rubber insulators, the chassis support brackets mounted right and left on the inside of the lower chassis, and the drive unit support brackets on the right and left sides of the drive unit case. The rubber mount assemblies also include some spacing shims, to evenly mount the drive unit.

Keep the bolt, washers, insulators, shims, and nut from each mount assembly together as each mount is removed. This is so they may be reinstalled in their original positions.
- 4.7 Place a floor jack under the drive unit assembly or attach the drive unit to an overhead crane.
- 4.8 Remove the drive shaft from the pinion shaft end yoke. (See SECTION 4, PART 4-1).
- 4.9 Remove 8 bolts (4 each side) which connect drive axle housings to lower chassis frame. Jack or block up rear of vehicle to remove the drive unit assembly.
- 4.10 Using overhead crane or floor jack, remove entire drive unit assembly from vehicle.

5. REMOVAL OF DRIVE UNIT FROM CASE:

See Fig. 9 & Fig. 10

- 5.1 Mount the drive unit assembly on a bench or stand with the drive axle assemblies free.

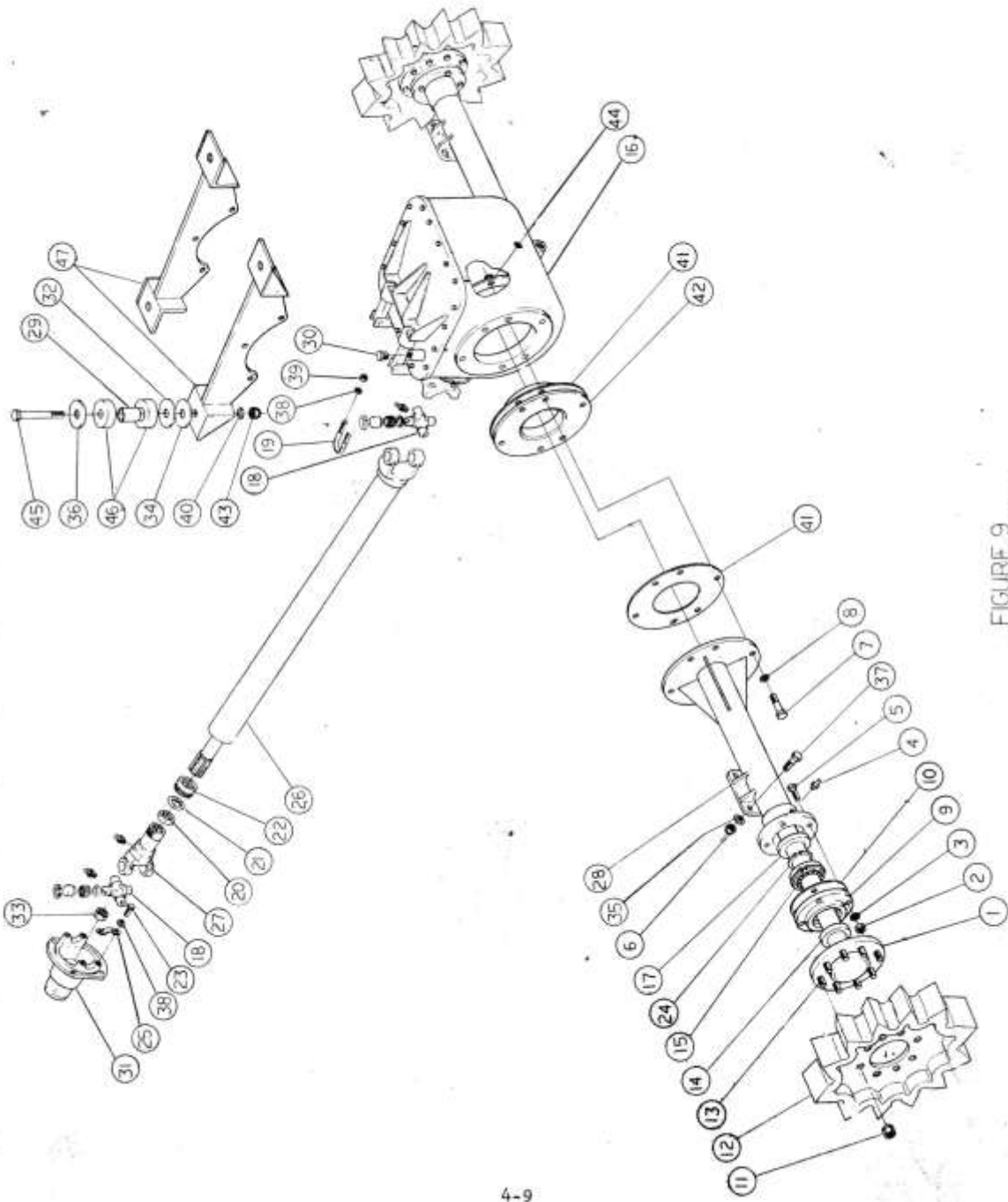

FIGURE 9
DRIVE LINE ASSEMBLY

DRIVE LINE ASSEMBLY

SEE FIG. 9

ITEM	PART NO.	QTY.	DESCRIPTION
1	1209130	2	Axle
2	01552-38	8	Hex. Nut, 3/8 - 24 NF
3	01554-8	8	Lock Washer, 3/8 Med.
4	0101281	2	Grease Fitting
5	01500-70	8	Cap Screw, 3/8 - 24 NF x 1 1/4 LG.
6	01525-41	8	Elastic Stop Nut, 9/16 - 18 NF
7	01505-198	12	Hex. Hd. Cap Screw, 5/8 - 11 NC x 3 LG.
8	01554-12	12	Lock Washer, 5/8 Med.
9	1209067	2	Retainer Plate
10	1209069	2	Gasket
11	0205009	16	Lug Nut, 30 Degree, 1/2 - 20 NF
12	1209076-7	2	Drive Sprocket
13	1205050	16	Stud
14	0101493	2	Seal, Outboard
15	0101739	2	Bearing
16	1219558	1	Drive Unit Assy.
17	0101492	2	Seal Inboard
18	0609042-3	2	Journal & Bearing Kit
19	1209091	2	U-Bolt
20	1209090-3	1	Washer, Cork
21	1209089-3	1	Washer, Steel
22	0609044	1	Dust Cap
23	01501-42	4	Cap Screw, 5/16 - 18 NC x 1 1/2 LG.
24	0122022	2	Retainer Ring
25	2109084	2	Retainer
26	2109085-3	1	Drive Shaft
27	1209088-3	1	Sleeve Yoke Assembly

ITEM	PART NO.	QTY.	DESCRIPTION
28	1209132-3	2	Axle Housing
29	0607012	4	Sleeve
30	1209234	1	Breather
31		1	Flange Yoke (Ford # Ditz 7089-C)
32	2109082-3	NR	Shim, 11 GA.
33		1	Hex. Nut (Ford #351165-58) 1/2 - 20 NF
34	2109082-1	NR	Shim, 1G GA.
35	01550-12	16	Washer, Flat, 9/16 Small
36	0607015	4	Washer
37	01504-163	8	Hex. Hd. Cap Screw, 9/16 - 18 NF x 1 3/4 LG.
38	01554-7	4	Split Lock Washer, 5/16 Med.
39	01520-7	4	Hex. Nut, 5/16 - 18 NC
40	01551-7	4	Washer, Flat, 7/16 LG.
41	1209134	4	Gasket
42	1209094	2	Bearing Retainer
43	01525-39	4	Elastic Stop Nut, 7/16 - 20 NF
44	1209255	2	Sector, Nut Holding
45	01500-111	4	Cap Screw, 7/16 - 20 NF x 3 3/4 LG.
46	0607006	8	Insulator
47	1209246	2	Drive Unit Support Bracket

- 5.2 Remove the 8 bolts (4 each side) which connect drive axle assembly to axle housings.
- 5.3 Remove drive axles from axle housings.
- 5.4 Remove the 2 steering band adjusting nuts.
- 5.5 Remove the steering lever and pushrod assemblies.
- 5.6 Remove the drive unit case lid (18 bolts).
- 5.7 Remove 6 bolts (3 each side) which connect drive unit case support brackets to drive unit case and remove brackets.
- 5.8 Unlock and remove 8 bolts in pinion shaft mounting assembly and pull complete pinion assembly from case. Save the shim pack. If difficulty is encountered removing the pinion assembly, two threaded holes have been drilled in the pinion assembly bearing retainer to aid removal. The holes are tapped for a 3/8 - 1 6 NC bolt.
- 5.9 Remove remaining 6 bolts (3 each side) which connect axle housings to drive unit case.
- 5.10 Remove axle housing.
- 5.11 Remove seals from axle housings.
- 5.12 Remove the bearing retainers (2). If difficulty is encountered, two threaded holes have been drilled in each bearing retainer.
- 5.13 Disconnect brake band rods from steering brake bands and remove rods and springs.
- 5.14 Disconnect steering brake bands from anchor plates and remove bands.
- 5.15 Remove 8 bolts (4 each plate) connecting anchor plates to drive unit case.
- 5.16 Attach lifting sling to drive unit assembly and attach sling to overhead crane or winch.
- 5.17 Remove drive unit assembly from drive unit case. Tilt the unit toward the ring gear side and it will clear the sides of the case. Once the unit is out of the case, set it in a stable place and substitute the double chain sling for all further lifting of the drive unit assembly outside of the case.

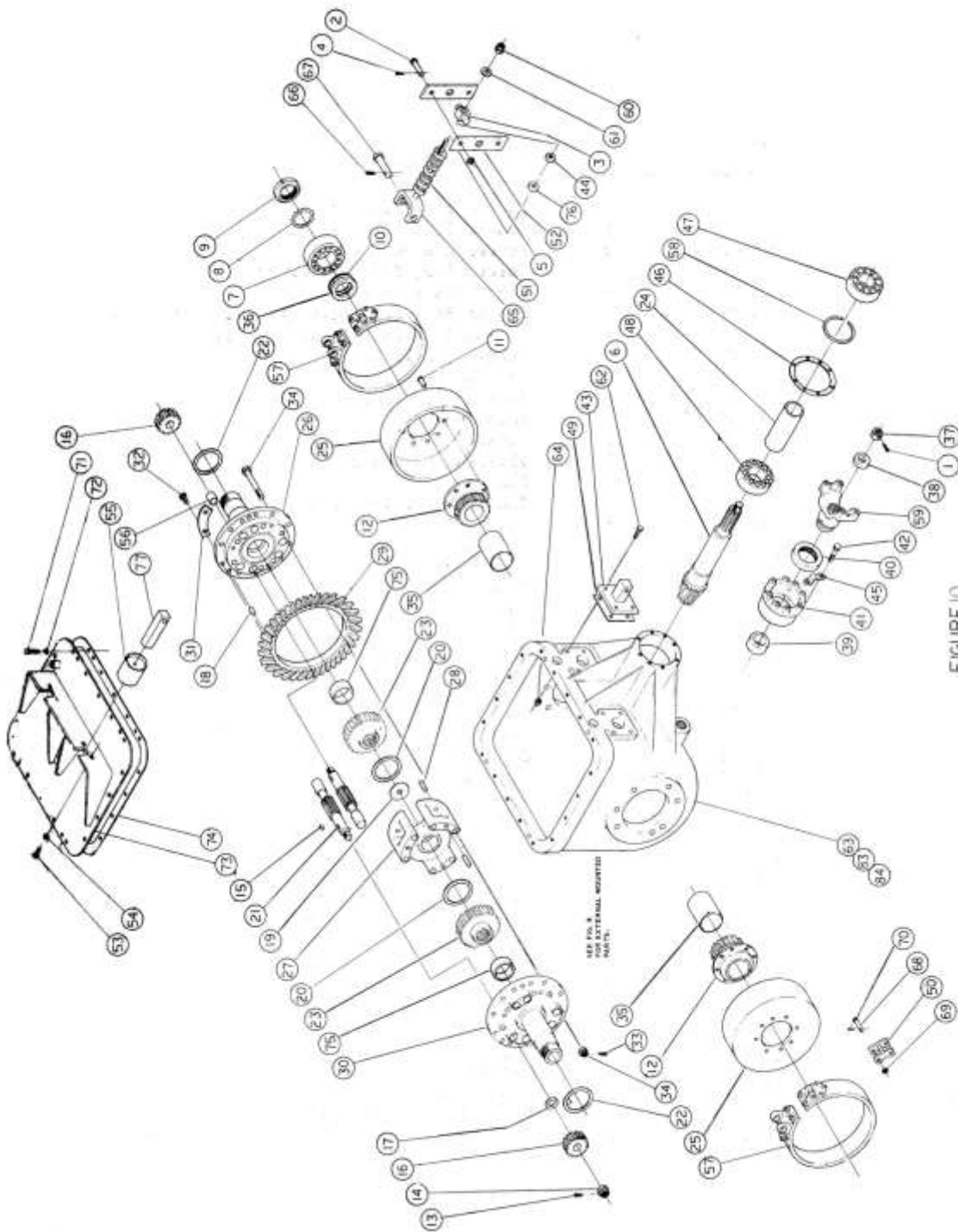

FIGURE 10
DRIVE UNIT ASSEMBLY

DRIVE UNIT ASSEMBLY

SEE FIG. 10

ITEM NUMBER	PART NUMBER	QTY.	DESCRIPTION
1	01541-107	1	Cotter Pin, 1/8 dia. x 2 Lg.
2	01540-352	4	Clevis Pin, 1/2 x 1.531 Grip
3	1209093	2	Trunnion Block
4	01541-82	4	Cotter Pin, 3/32 dia. x 3/4 Lg.
5	01550-11	4	Flat Washer, 1/2 Small
6	1209129	1	Pinion Shaft, 7 Tooth (Oliver #176 953-A) Used, with 6.14 Gear Ratio
7	1209172	2	Bearing, Ball
8	1209171	2	Lock Washer, Bearing
9	1209170	2	Bearing Lock Nut
10	1209169	2	Shim Pack
11	1209168	16	Rivet
12	1209167	2	Steering Drum Gear
13	1209166	6	Pin
14	1209165	6	Compensating Pinion Nut
15	1209164	6	Woodruff Key
16	1209163	6	Compensating Pinion
17	1209162	6	Flat Washer Spacer
18	1209161	3	Dowel
19	1209160	1	Washer
20	1209159	2	Spacer Washer
21	1209158	6	Compensating Internal Pinion
22	1209157	2	Washer, Steering Drum
23	1209156	2	Gear
24	1209128	1	Pinion Spacer, (Used with 6.14 Gear Ratio)
25	1209155	2	Steering Drum
26	1209154	1	Cover, R.H.
27	1209153	1	Compensating Case
28	1209152	6	Dowel
29	1209119	1	Gear, Differential Bevel, 43 Tooth (Oliver #176952-A) Used With 6.14 Gear Ratio
30	1209150	1	Cover, L.H.
31	1209149	6	Lock Plate
32	1209148	12	Lock Plate Bolt
33	1209147	6	Pin
34	1209146	6	Compensating Case Bolt & Nut
35	1209145	2	Bushing
36	1209144	2	Spacer Washer
37	1209096	1	Nut, Pinion Shaft
38	1209097	1	Spacer
39	1209098	1	Spacer
40	1209099	1	Oil Seal
41	1209124	1	Bearing Housing (Used on Drive Units With 6.14 Gear Ratio)
42	01505-73	8	Hex. Hd. Cap Screw, 3/8-16 NC x 1 3/4 Lg.

ITEM NUMBER	PART NUMBER	QTY.	DESCRIPTION
43	1209204	2	Anchor
44	0609106	2	Seal, Steering Band Rod
45	0109017	4	Lock Plate
46	1209103	1	Shim Pack
47	1209104	1	Bearing, Ball
48	1209143	1	Bearing, Roller
49	1209125	2	Gasket, Anchor
50	1209105	2	Link, Anchor
51	0609105	2	Spring
52	1209113	4	Lever, Steering
53	01501-5	4	Hex. Hd. Cap Screw, 1/4-20 NC x 5/8 Lg.
54	01554-6	4	Split Lock Washer, 1/4 Med.
55	1209114	2	Slave Cylinder
56	1209142	12	Bushing
57	1209115-2	2	Steering Band Assy.
58	1209123	1	Snap Ring (Used on Drive Units With 6.14 Gear Ratio)
59	1209120-3	1	End Yoke
60	01525-40	2	Elastic Stop Nut, 1/2 - 20 NF
61	1209121	2	Spacer
62	01500-72	8	Hex. Hd. Cap Screw, 3/8 - 24 NF x 1 1/2 Lg.
63	1209182-7	1	Drive Unit Case
64	01525-38	8	Elastic Stop Nut, 3/8 - 24 NF
65	1209107	2	Rod, Brake Band
66	01541-104	2	Cotter Pin, 1/8 dia. x 1 1/4 Lg.
67	01540-538	2	Clevis Pin, 3/4 x 3.156 Grip
68	01540-213	4	Clevis Pin, 3/8 x 1.594 Grip
69	01558-2	4	Flat Washer
70	01541-83	4	Cotter Pin, 3/32 dia. x 1 Lg.
71	01501-36	18	Hex. Hd. Cap Screw, 5/16 - 18 NC x 3/4 Lg.
72	01554-7	18	Split Lock Washer, 5/16 Med.
73	1209190	1	Drive Unit Cover
74	1209192	1	Gasket, Cover
75	1209141	2	Compensating Case Bushing
76	1209077	2	Spacer, 1/4 Thick
77	1209133	2	Push Rod
78	1209197-3	4	Dowel Pin

6. DRIVE UNIT AND COMPENSATING CASE DISASSEMBLY:

See Fig. 10 & Fig. 11

- 6.1 Remove bearing locknuts and locking washers from both sides of drive unit assembly.
- 6.2 Use a puller to remove bearings from both sides of drive unit assembly.
- 6.3 Remove spacing washers and shims, taking care to keep right and left shim packs together so they may be reinstalled in their original positions.
- 6.4 Slide off steering drums.
- 6.5 Remove the cotter pins from 6 external pinion nuts (3 each side) and remove 6 pinion nuts.
- 6.6 Remove 6 external pinions (3 each side) with suitable puller.
- 6.7 Remove Woodruff keys and washers.
- 6.8 Mark compensating case in its original position with center punch.
- 6.9 Remove 6 bolts (3 each side) holding compensating case together. Internal pinions and compensating gears can now be removed for bushing inspection.

7. DRIVE AXLE DISASSEMBLY:

See Fig. 9

- 7.1 Remove drive sprockets.
- 7.2 Remove snap ring.
- 7.3 Press bearing off.
- 7.4 Remove the bearing retainer and then remove the seal from the retainer.

8. PINION DISASSEMBLY:

See Fig. 10

- 8.1 Remove the cotter pin.
- 8.2 Remove the castle nut.
- 8.3 Remove spacer.
- 8.4 Remove the yoke.
- 8.5 Remove spacer.

FIGURE 11: COMPENSATING CASE ASSEMBLY

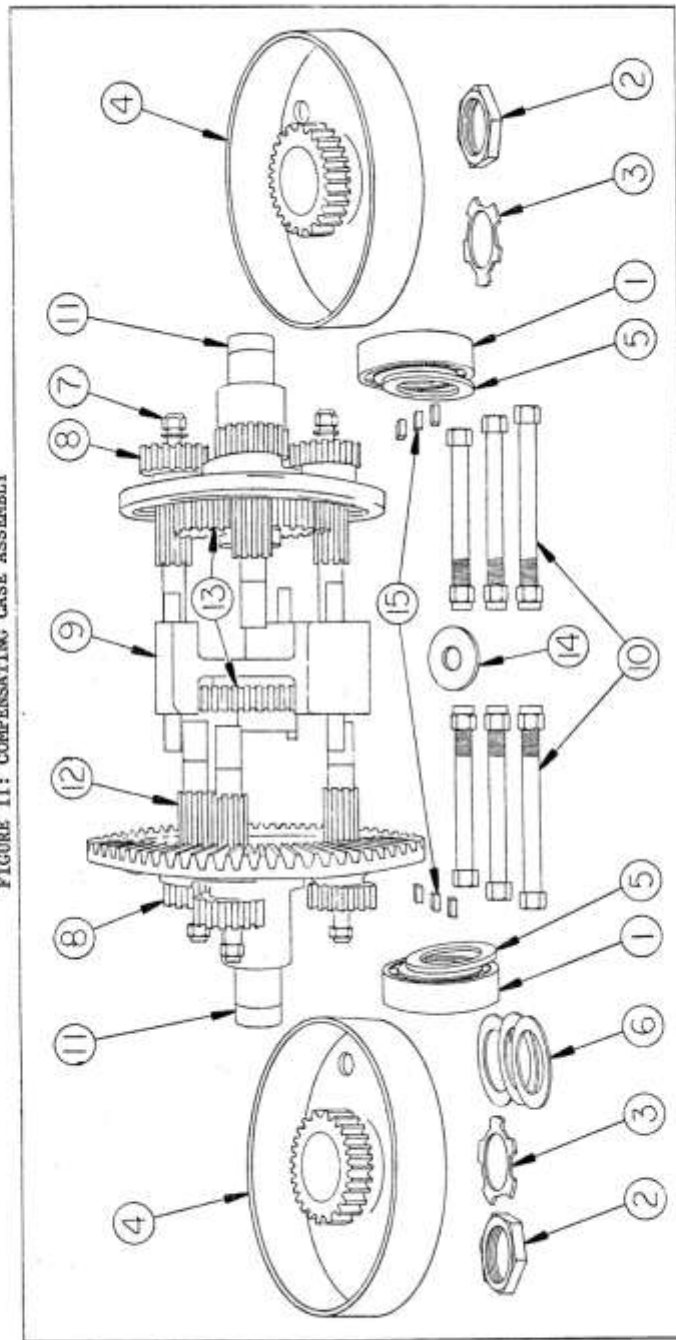

- 1. Differential Bearing
- 2. Lock Nut
- 3. Lock
- 4. Steering Drum
- 5. Spacer

- 6. Shims, as required
- 7. External Pinion Nut
- 8. External Pinion
- 9. Compensating Case
- 10. Case Bolt

- 11. Compensating Case Covers
- 12. Internal Pinion
- 13. Compensating Gear
- 14. Compensating Gear Washer
- 15. External Pinion Key

- 8.6 Press off bearing housing.
- 8.7 Remove snap ring from bearing housing, then remove bearing and seal from bearing housing.
- 8.8 Remove the long spacer.
- 8.9 Press off the roller bearing on pinion shaft.

9. CHECKING BEARING FIT:

9.1 General:

Thiokol recommends replacement of all bearings whenever the steering differential is disassembled for major servicing. However, even though the vehicle owner may intend to install all new bearings, the old bearings should be inspected for signs of unusual wear. In some cases, bearings inspected may have a brownish discoloration or film either on the outer face of the outer bearing race or on the inner face of the inner bearing race. This brownish discoloration indicates abnormal slipping is occurring between the outer bearing race and the bearing housing or the inner race and the shaft or hub on which the bearing is mounted. Within the steering differential, there are some critical areas of inspection with regard to bearing fit.

NOTE: ACCURATE MEASUREMENT OF THE AREAS LISTED BELOW REQUIRES PRECISION MEASURING INSTRUMENTS CALIBRATED TO A KNOWN STANDARD. AN OUTSIDE MICROMETER IS NEEDED FOR MEASURING SHAFT DIAMETERS. AN INSIDE MICROMETER OR DIAL BORE GAUGE IS NEEDED FOR MEASURING HOUSING DIAMETERS. BEFORE ANY SUCH MEASUREMENTS ARE TAKEN, THE STEERING DIFFERENTIAL SHOULD BE ALLOWED TO STAND AT ROOM TEMPERATURE (60-80 DEGREES) FOR 6 HOURS.

9.2 Critical areas and their respective measurements:

- 9.2.1 Outside diameter of the pinion shaft at the point where the pinion roller bearings are mounted. Measurement: 1.9684" to 1.9688".
- 9.2.2 Outside diameter of the pinion shaft at the point where the pinion ball bearings are mounted. Measurement: 1.7715" to 1.7720"
- 9.2.3 Outside diameter of the shaft on which the drive unit assembly ball bearings are mounted. Measurement: 2.1653" to 2.1659".
- 9.2.4 Outside diameter of the drive axle shafts at the point where the ball bearings are mounted. Measurement: 1.9684" to 1.9689".

- 9.2.5 Inside diameter of the drive unit case pinion housing at the point where the roller bearings seat. Measurement 4.3307" to 4.3316".
- 9.2.6 Inside diameter of the pinion bearing housing at the point where the ball bearings seat. Measurement: 3.9369" to 3.9377".
- 9.2.7 Inside diameter of the bearing retainers at the point where the drive unit assembly ball bearings seat. Measurement: 4.7243" to 4.7251".
- 9.2.8 Inside diameter of the drive axle housings at the point where the drive axle bearings seat. Measurement: 3.5432" to 3.5440".

If the steering differential has a bearing problem and inspection of the unit reveals measurements which are not within the tolerances listed above, contact the Thiokol factory service department.

10. STANDARD REPLACEMENT PARTS:

Thiokol recommends that all gaskets, seals, ball and roller bearings, unitorque nuts and elastic stopnuts be replaced when the steering differential is re-assembled. Replacement of these parts will extend the service life of the differential. A list of standard replacement parts, including part number, quantity required and part description, follows:

<u>PART NO.</u>	<u>QTY.</u>	<u>DESCRIPTION</u>
01525-40	2	1/2-20 NF elastic stop nut, steering band adjusting nut.
01525-38	8	3/8-24 NF elastic stop nut for bolts connecting anchor plate to drive unit case.
01525-41	8	9/16-18 NF elastic stopnut for bolts which connect axle housing mounting brackets to lower chassis frame.
01525-39	4	7/16-20 NF elastic stopnut for bolts which connect drive unit case mounting brackets to chassis.
0609106	2	Steering band rod seal.
1209099	1	Drive pinion assembly oil seal.
0101492	2	Drive axle assembly oil seal, inboard.
0101493	2	Drive axle assembly oil seal, outboard.
1209172	2	Ball bearings, main drive unit assembly bearings.
1209104	1	Ball bearings, drive pinion assembly.

TOOTH CONTACT PATTERNS TELL THE STORY ON DIFFERENTIAL WEAR

When you're repairing or rebuilding any differential, it's a good idea to look at the contact patterns on the individual teeth of the gears.

Shown below are a number of undesirable tooth wear patterns as they appear on the driven gear, along with an explanation of why they formed ... and suggested remedies for their correction.

Of course, the correct tooth contact pattern must be maintained for top performance.

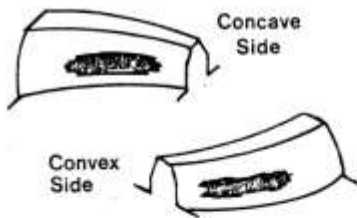

Correct tooth contact patterns will look like this (on the driven gear) with accurate and rigid mounting.

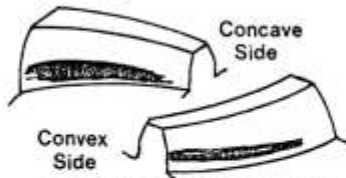

OUT OF POSITION PATTERNS

Cause: Pinion too far from cone center.

Remedy: Move pinion toward cone center.

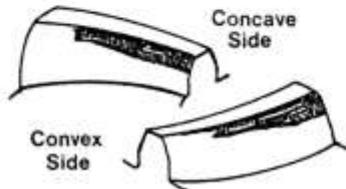

OUT OF POSITION PATTERN

Cause: Pinion too close to cone center.

Remedy: Move pinion away from cone center.

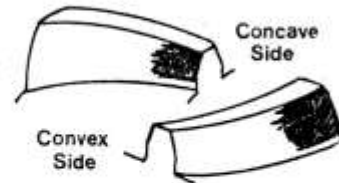

CROSS PATTERN

Cause: Shafts do not intersect.

Remedy: Line up shafts.

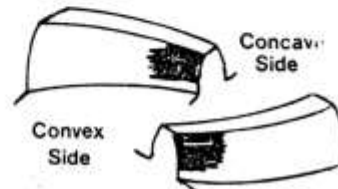

TOE PATTERN

Cause: Shaft angle too large.

Remedy: Correct the shaft angle
crease backlash.

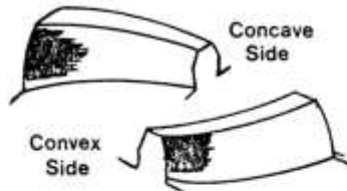

CROSS PATTERN

Cause: Shafts do not intersect.

Remedy: Line up shafts.

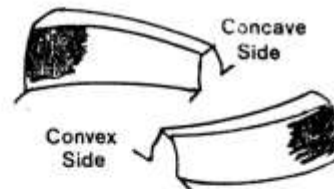

HEEL PATTERN

Cause: Shaft angle too small.

Remedy: Correct the shaft angle
Decrease toward minimum backlash.

<u>PART NO.</u>	<u>QTY.</u>	<u>DESCRIPTION</u>
1209143	1	Roller bearings, drive pinion assembly.
0101739	2	Ball bearings, drive axle.
1209125	2	Gasket, anchor plate.
1209192	1	Gasket, drive unit case lid.
1209134-1	4	Gasket, install between drive unit case and bearing retainer and between bearing retainer and axle housing.
1209127	2	Gasket, install between drive axle assembly and axle housing.

11. COMPENSATING CASE COVER BUSHING REPLACEMENT:

See Fig. 12

The compensating case cover internal pinion bushings should give a .004 to .005 inch clearance. If bushings are found to be worn beyond this tolerance, they should be replaced. Be sure to drill new oil holes when installing new bushings. After oil holes have been drilled, the compensating case should be bolted together and the bushings line reamed to give a .004 to .005 inch clearance.

New steering drum bushings will not have to be reamed after installation if care is used when pressing the bushings in.

12.. DRIVE UNIT AND COMPENSATING CASE ASSEMBLY:

See Fig. 11 and Fig. 13

12.1 Stand compensating cover on end with ring rear teeth facing up.

12.2 Install compensating gear with long bearing side into cover (facing down).

12.3 Install compensating gear washer on short bearing side (facing up).

12.4 Install compensating case and center spacing washer.

12.5 Install other compensating gear with short bearing side and compensating gear washer into case.

12.6 Install internal pinions, alternating threaded and tapered end up with plain end up. Align keyways with center of compensating case, keyways facing away from the center forming a "Y" along imaginary lines radiating from the center.

FIGURE 12: COMPENSATING CASE COVER BUSHINGS

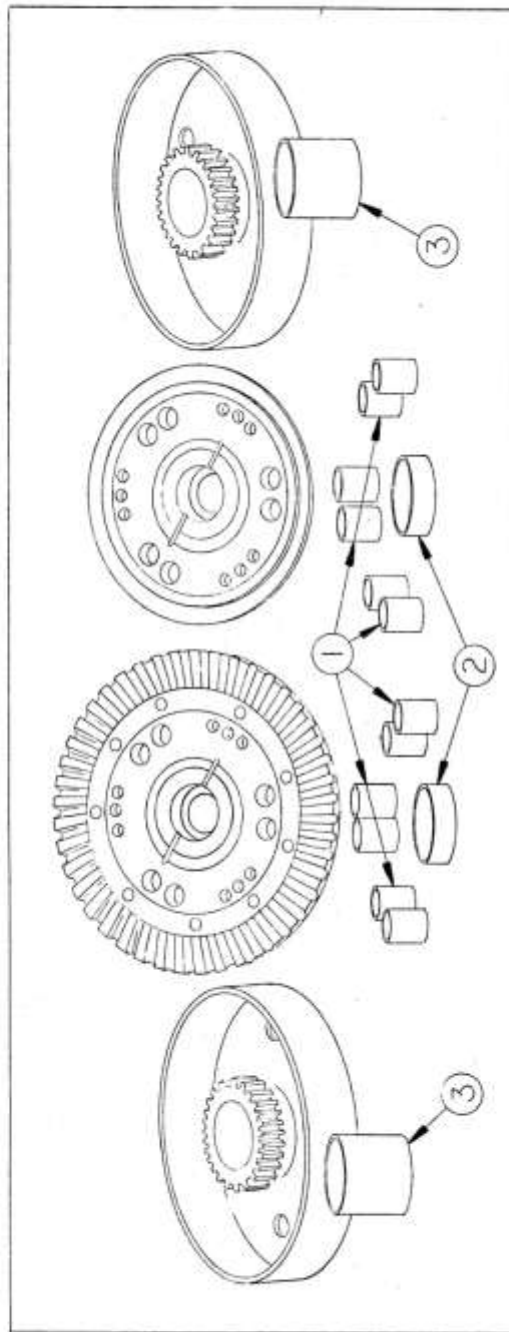

1. Case Cover Pinion Bushings.
2. Compensating Case Bushings.
3. Steering Drum Gear Bushings.

NOTE: KEYWAYS CANNOT BE ALIGNED EXACTLY STRAIGHT, BUT WILL BE OFF-CENTER ABOUT ONE-HALF TOOTH.

- 12.7 Install the other compensating case cover and three of the case thru-bolts and castle nuts. Heads of bolts must be next to the tapered and threaded ends of internal pinions.
 - 12.8 Drive 3 case cover dowels into place and stake with punch.
 - 12.9 Place 3 flat washers on tapered and threaded ends of internal pinion shafts, install three Woodruff Keys, Install 3 external pinion gears with widest end of tapered hole down, and install three castle nuts over the external pinion gears and snug tight.
 - 12.10 Turn compensating case assembly end for end, install the remaining 3 thru-bolts and castle nuts, and repeat steps H. and I.
 - 12.11 Torque the 6 thru-bolts to 152-168 ft./lbs. Set castle nuts with slots over cotter pin holes.
 - 12.12 Torque the 6 castle nuts on external pinions to 100 ft./lbs. Set castle nuts with slots over cotter pin holes.
 - 12.13 Install cotter pins on the 6 thru-bolt castle nuts and the 6 external pinion castle nuts.
 - 12.14 Check the assembly for free movement.
 - 12.15 Install a steering drum gear washer on each end of the assembly and a steering drum assembly on each end of the drive unit assembly.
 - 12.16 Complete the assembly by installing spacers, ball bearings, lock washers and locknuts in their original positions. DO NOT INSTALL SHIMS AT THIS POINT, THEY WILL BE INSTALLED AFTER DRIVE UNIT HAS BEEN MEASURED AND SHIM PACK HAS BEEN DETERMINED.
13. DRIVE AXLE ASSEMBLY:
- See Fig. 9
- 13.1 Install seal in bearing retainer plate, seal lip out.
 - 13.2 Slide retainer plate onto axle shaft.
 - 13.3 Press bearings onto axle shaft.
 - 13.4 Install snap ring onto axle shaft. Make sure assembly is snug against retainer plate.

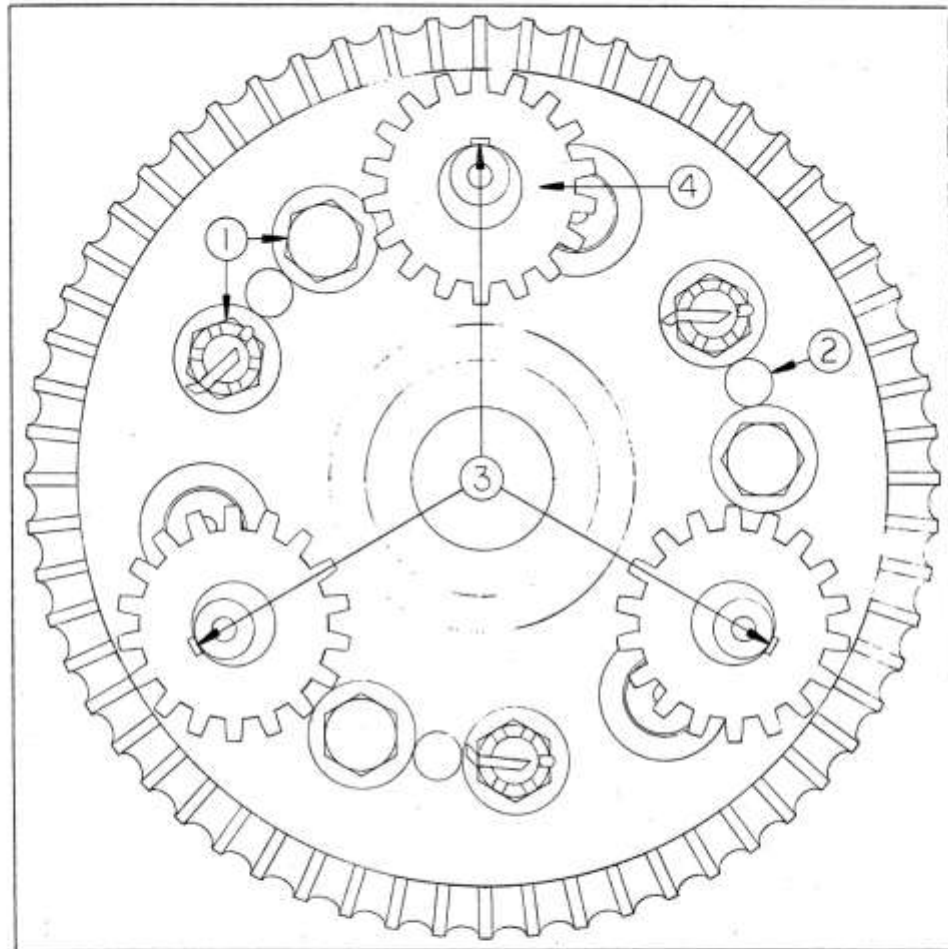

FIGURE 13

1. Compensating case thru bolts.
2. Dowel.
3. Keyways in line with center.
4. External pinion.

14. PINION ASSEMBLY:

See Fig. 10

- 14.1 Press roller bearing onto pinion shaft, with chamfer on inner bearing race facing pinion teeth.
- 14.2 Install large spacer with relief end facing toward the pinion gear.
- 14.3 Install seal in bearing housing.
- 14.4 Install ball bearing in bearing housing.
- 14.5 Install snap ring in bearing housing.
- 14.6 Press bearing housing assembly onto pinion shaft.
- 14.7 Install spacer and end yoke.
- 14.8 Install spacer and pinion shaft nut. Tighten nut and align with cotter pin holes.
- 14.9 Install cotter pin.

15. MEASURING DRIVE UNIT ASSEMBLY:

See Fig. 14 and Fig. 15

- 15.1 Stand the completed drive unit assembly, minus shims, on end with an outer bearing race resting on two parallels on surface plate. It doesn't really matter which end, but the unit will be more stable if the ring gear side is down (gear teeth facing up).
- 15.2 Using height gauge, measure distance from outer bearing race to outer bearing race. Compute the distance to thousandths of an inch (three decimal places).

NOTE: COMPLETE DRIVE UNIT ASSEMBLIES SHIPPED FROM THIOKOL ARE PRE-MEASURED AT THE FACTORY, WITH THE WIDTH DIMENSION WITHOUT SHIMS ETCHED ON THE RING GEAR.

16. DETERMINING SHIM PACK FOR DRIVE UNIT ASSEMBLY:

- 16.1 Record the drive unit case width. Width is stamped on the upper right rear of the case, just below the case lid mounting face.
- 16.2 Record the bearing retainer dimensions stamped on the outer edge.
- 16.3 Record the width of the drive unit assembly.
 - 16.3.1 Use the figure obtained in Item 15 if you are working with a rebuilt unit.

FIG. 14



FIG. 15

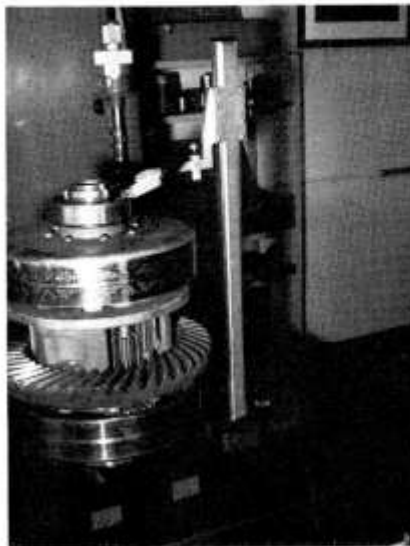

- 16.3.2 Use the figure etched on the ring gear if you are working with a new unit supplied by Thiokol. The figure is etched in this format: "TC 14.xxx W/O", W/O" meaning "without shims".
- 16.4 Add the two bearing retainer dimensions together.
- 16.5 Subtract total in step D. from the case width (step 1).
- 16.6 To account for the thickness of the gaskets used between the bearing retainers and the drive unit case, add .030 (.015 for each gasket) to the figure from step E. Round off figure to 3 decimal places.
- 16.7 Subtract drive unit assembly width (step C.) from the figure obtained in step F. The resultant figure is the total shim width needed. Divide this figure by 2 to get the shim width for each side of the drive unit assembly.

EXAMPLE:

Drive unit case width (step A.) is 16.6159

Bearing retainer dimensions (step B.) are .9074 and .9077

Drive unit assembly width (step C.) is 14.759

Step D. Add bearing retainer dimensions	.9074
	<u>+ .9077</u>
	1.8151

Step E. Subtract total in Step D. (1.8151) from case width (16.6159)	16.6159
	<u>-1.8151</u>
	14.8008

Step F. Add thickness of two gaskets to figure obtained in Step 5 (.015 + .015 = .030) and round off to 3 decimal places.	14.8008
	<u>+ .030</u>
	14.831

Step G. Subtract drive unit assembly width (Step C.) from figure obtained in Step F.	14.831
	<u>-14.759</u>
	.072

Divide the figure above by 2 and you have the width of the shim packs for the right and left sides of the drive unit assembly.	.036
	<u>21.072</u>

17. MEASURING PINION MOUNTING DEPTH AND SHIM PACK:

- 17.1 Stand pinion assembly on surface plate with gear end up.
- 17.2 Using height gauge, measure distance from bearing housing inner mounting faced to inner roller bearing race (inner race faces pinion gear).
- 17.3 Add 6.375 to dimension obtained in Step B. 6.375 inches is the distance from the center of the differential bearing bores to the forward face of the pinion gear.
- 17.4 Subtract the figure obtained in Step 3 from the number stamped on the drive unit case pinion housing. The difference obtained is the width of the shim pack needed.

18. ASSEMBLY OF STEERING DIFFERENTIAL:

The following procedure assumes that drive unit assembly width, pinion mounting depth, and shim pack widths have been determined at the appropriate assembly stage.

NOTE: UNLESS OTHERWISE SPECIFIED, LUBRICATE ALL BOLT THREADS WITH MOLYLUBE ANTI-SEIZE BEFORE INSTALLATION.

- 18.1 Remove bearing locknuts, locking washers and bearings from drive unit assembly, and add shim packs as determined in Item XVI.

FIG. 16

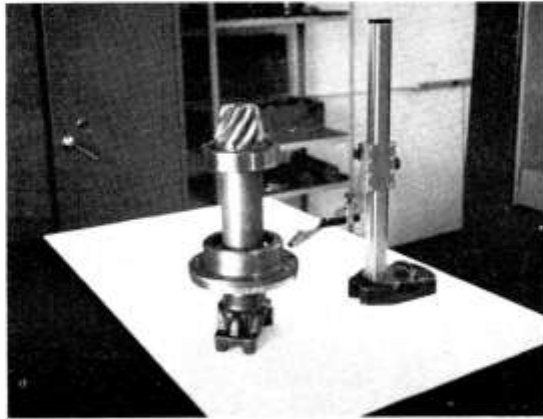
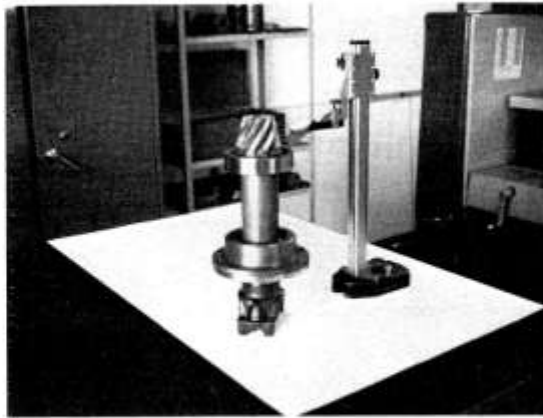

FIG. 17



- 18.2 Reinstall bearings, locking washers, and bearing locknuts to drive unit. DO NOT LOCK WASHERS YET!
- 18.3 Inspect drive unit case to make certain no washers, nuts or debris have fallen into case.
- 18.4 Attach double chain lifting sling (part #2130037 or alternative) to drive unit assembly.
- 18.5 Attach steering bands to steering drums using steering band securing hooks (Part #2130027 or alternative.).
- 18.6 Lower drive unit assembly until it comes to rest on top of drive unit case and substitute lifting sling (Part #2130038 or alternative) for double chain sling.
- 18.7 Lower the drive unit assembly into case. Tilt unit toward the ring gear side as it is being lowered and it will clear the sides of the case.
- 18.8 Still supporting drive unit with sling, Install bearing retainers. Use a soft mallet to seat retainers. No gasket sealer is used with these gaskets.
- 18.9 Remove sling and using 6 (3 each side) of the 12 bolts which will later mount drive axles, mount brackets, as well as the bearing retainers all to the drive unit case, temporarily mount the bearing retainers to the drive unit case. Use nut wrench tools (Part #2130034) or the old nut plate, and torque the bolts to 50 ft. lbs.
- 18.10 Install drive pinion assembly with shims to drive unit case. Use No. 2 gasket sealer on case pinion assembly mounting face. Install locks and 8 bolts. Torque bolts to 21 ft. lbs. Do not lock bolts yet.
- 18.11 Measure backlash:

18.11.1 General:

Backlash is the slack or play between meshing gear teeth, in this case the play between any drive pinion tooth and the 2 ring gear teeth it happens to be between.

The amount of backlash is determined by rocking the ring gear back and forth while holding the pinion stationary and measuring the distance the ring gear travels as a drive pinion tooth is contacted by one and then the other of the two ring gear teeth it happens to be between.

Minimum backlash in this unit is .006" to .009" with no more than .008" difference between the minimum and maximum readings. Example: minimum backlash is found to be .007". Maximum backlash should be no greater than .015" (.007" + .008").

In this unit backlash is adjusted by redistributing the drive unit shims, that is, taking shims from one side and adding them to the other. Adding shims to the ring gear side will decrease backlash, subtracting shims from the ring gear side will increase backlash. The change in shim pack should be about $1\frac{1}{2}$ times the backlash error.

18.11.2 Procedure:

See Fig. 18

- 18.11.2.1 Clamp dial indicator to drive unit case as shown and position dial indicator head so that it contacts a ring gear tooth. Mark this first ring gear tooth to be measured with chalk or a marking pen.
- 18.11.2.2 Place the right hand on pinion end yoke, and hold the pinion stationary.
- 18.11.2.3 With left hand rotate ring gear counter-clockwise until pinion is engaged and ring gear stops. Zero the dial indicator at this point, then rotate the ring gear clockwise until the pinion is again engaged and the ring gear stops. Take reading on dial indicator. For optimum accuracy take several readings on each tooth measured.
- 18.11.2.4 Lift the dial indicator point clear of the ring gear teeth and rotate the pinion clockwise until the ring gear is 4 or 5 teeth away from the chalk mark. Reposition the dial indicator point so that it contacts this 4th or 5th tooth and repeat steps b & c immediately above.

Repeat this procedure until one full revolution of the ring gear is obtained.

18.11.3 If backlash is not within specifications:

- 18.11.3.1 Supporting the drive unit, (Part no. 2130030 or alternate) remove bearing retainers (See Item 5.12 above) and using the special tool (Part #2130031)

FIG. 18



remove the bearing lock nuts. Then remove the lock washer, and bearings, and redistribute the shims as needed. Then reassemble the unit.

- 18.11.3.2 If the special tool (Part #2130031) is not available then the drive unit must be removed from its case in order to redistribute shims.

To remove and reinstall drive unit:

- 18.11.3.2.1 Remove bearing retainers (See Item 5.12 above)
- 18.11.3.2.2 Remove the drive pinion (See Item 5.8 above)
- 18.11.3.2.3 Remove the drive unit from case (See Item 5.16 & 5.17 above)
- 18.11.3.2.4 Remove locknuts, lockwashers, and bearings and redistribute the shims as needed.
- 18.11.3.2.5 Reassemble drive unit and re-install drive unit, bearing retainers, and drive pinion to case. (See Items 18.1 & 18.10 above)

- 18.11.3.3 Repeat backlash measuring procedure. (See Item 18.11.1 & 18.11.2 above)
- 18.11.3.4 If backlash is still not right, repeat items 18.11.3.1 through 18.11.3.3 immediately above as needed until backlash is within specifications.

NOTE: Before proceeding with Step 18.12 below, the unit should be at this stage of completion:

Drive unit should be installed into case with steering bands and with correct shim pack. Bearing locknuts should be unlocked. The bearing retainers should be installed into the case with 6 bolts (3 each side) torqued to 50 ft. lbs., and drive pinion and shims should be installed into the case with 4 lock plates and 8 bolts torqued to 21 ft. lbs. Drive pinion bolts also should not be locked yet.

- 18.12 Lock bearing locknut into place on drive unit with lockwasher.
- 18.13 Remove the bolts, nuts, or nut plates from the bearing retainers.
- 18.14 Install new brake band rod seals.
- 18.15 Install anchor plates with gaskets. Coat bolts with B.K. NO. 2 gasket sealer, but do not use sealer on gaskets. Torque bolts to 21 ft. lbs. Install anchor links to anchor plates using clevis and cotter pins.
- 18.16 Secure steering brake bands to anchor links with clevis and cotter pins. Install brake band rods, springs and spacers with clevis and cotter pins. To protect brake band rod seals during brake band rod installation, cover rod threads with shim stock or heavy gauge aluminum foil before inserting rods through seals.
- 18.17 Install steering lever and pushrod assemblies to anchor plates with clevis and cotter pins.
- 18.18 Install new $\frac{1}{2}$ - 20 elastic NF stopnuts on each steering brake band rod. (NOTE: See procedure for adjusting steering bands using steering band adjusting nuts -- Item 25, this SECTION)
- 18.19 Install drive axle housings with gaskets and drive unit support brackets. Use B.K. No. 2 gasket sealer on both sides of gaskets. If using old nut plate coat end threads of 5 bolts with loc-tite and threads below shoulder bolts with No. 2 gasket sealer. Torque bolts to 130 ft. lbs.

Axle housings should be mounted with chassis mounting plate vertical and facing the front of the vehicle.

- 18.20 Install drive axle assemblies with gaskets. Use B. K. no. 2 gasket sealer on both sides of gaskets. Torque bolts to 21 ft. lbs.
- 18.21 Install drive unit case lid with gasket. New gaskets must have four additional holes punched in them during installation to accommodate dowel pins. Torque bolts to 12 ft. lbs.
- 18.22 Install drive sprockets. Torque nuts to 70 ft. lbs.
19. INSTALLATION OF DRIVE UNIT ASSEMBLY:
- 19.1 Using overhead crane or floor jack, move the drive unit assembly to vehicle for installation. Rear of vehicle must be jacked up to install the assembly.
- 19.2 Mount drive axle housings to lower chassis frame. Torque bolts to 75 - 85 ft. lbs.
- 19.3 Mount drive unit support brackets to chassis, using rubber bushings, shims and bolts in their original positions. Torque bolts to 25 - 30 ft. lbs.
- 19.4 Mount steering slave cylinders in their original positions on drive unit case lid. Connect cooling system hoses to hose fittings on drive unit case. Connect wires to the temperature sending unit, the thermostat, and the heating unit.
- 19.5 Install the grid plate over drive unit assembly.
20. PROCEDURE FOR DETERMINING SHIM PACK ON DRIVE UNIT MOUNTS:
- If for some reason the original shims are not available, or if a new drive unit case or new drive unit support brackets are being used it would be necessary to determine shim packs for the four mounts holding the drive unit assembly to the chassis.
- 20.1 Using overhead crane or floor jack, move the drive unit assembly to vehicle for installation. Rear of vehicle must be jacked up to install the assembly.
- 20.2 Using floor jack or overhead crane to lift to correct height insert pins through holes in drive axle housing brackets and corresponding holes in lower frame mounting brackets to align, then clamp brackets with vise grips.
- 20.3 Measure distance between upper surface of chassis mount bracket and under surface of drive unit mount bracket at each hole (4 places).
- 20.4 Find each distance in left hand column of chart below and read which shims are required in the two right hand columns.

DISTANCE brkt. to brkt.	Total shim thickness	1/8 shims required	1/16 shims required
1"	0	0	0
1 1/16"	0	0	0
1 1/8"	1/16"	0	1
1 3/16"	1/8"	1	0
1 1/4"	3/16"	1	1
1 5/16"	1/4"	2	0
1 3/8"	5/16"	2	1
1 7/16"	3/8"	3	0
1 1/2"	7/16"	3	1

21.

BOLT AND PART #	QTY.	FUNCTION	TORQUE	SPECIAL INSTRUCTIONS
5/8 - 11 NC x 2-3/4 lg. Hex head cap screw #01505-198	12	Mount bearing retainers, axle housings, and drive unit support brackets to drive unit case	130 ft. lbs.	Coat end threads of 10 bolts going into old nut plate with Loc-tite 242 or 21. Coat threads of remaining 2 bolts with Molylube anti-seize. Also coat the threads of all bolts with B. K. no. 2 gasket sealer.
3/8-24 NF x 1-3/4 lg. Hex head capscrew #01500-70	8	Mount axle assembly to axle housing.	18-21 ft. lbs.	Lubricate threads with Molylube anti-seize
3/8-16 NC x 1-3/4 lg. Hex head cap screw #01505-73	8	Secure drive pinion assembly to drive unit case	21 ft. lbs.	Lubricate threads with Molylube anti-seize
3/8-24 NF x 1 1/2 lg. Hex head cap screw #	8	Mount steering band anchor plate to drive unit assembly	21 ft. lbs.	Coat threads with No.2 gasket sealer and Molylube anti-seize.
5/16-18 NC x 1 lg. Hex head cap screw #01501-36	18	Mount drive unit assembly case lid to drive unit assembly case.	12 ft. lbs.	Installed with Loc-tite 242 or 21
1/4-20 NC x 5/8 lg. Hex head cap screw #01501-5	4	Mount steering slave cylinders to drive unit assembly case lid.	Unnecessary	Lubricate threads with Molylube anti-seize.
9/16-18 NF x 1 1/2 lg. Hex head cap screw #01504-162	8	Mount drive unit assembly to vehicle lower chassis frame.	75 - 85 ft. lbs.	Lubricate threads with Molylube anti-seize.
7/16-20 NF x 3-3/4 lg. Hex head cap screw #01500-111	4	Mount drive unit assembly to vehicle chassis.	25 - 30 ft. lbs.	Lubricate threads with Molylube anti-seize.

22. SPECIFICATIONS:

LUBRICANT TYPE: Conoco DN-600 fluid or equivalent from -65° F. to 0° F.
Dectol 116 from 0° F. to 100° F. WARNING: SUBSTITUTION
OF LESSER QUALITY OIL MAY CAUSE PREMATURE DIFFERENTIAL
FAILURE.

LUBRICANT CAPACITY: Approximately 4 3/4 gallons.

LUBRICATION INTERVAL: Drain and refill every 150 hours of operation
and at the beginning of each operating season,
if vehicle is only used seasonally. NOTE: Under
normal operating conditions, check oil level
weekly. Under strenuous operating conditions,
check oil level every 2 days.

BACKLASH: .006" to .009" minimum with no more than .008" difference
between minimum and maximum backlash.

Example: Minimum backlash is found to be .007". Maximum
backlash should be no greater than .015" (.007"
+ .008")

STEERING DRUM RUNOUT: Face maximum .030"
Edge maximum .060"

FINAL DRIVE GEAR RATIO: 6.14 : 1

RING AND PINION GEAR: 6.14 differential has 7 tooth pinion and 43
tooth ring gear.

23. IN-VEHICLE ADJUSTMENTS AND REPAIRS:

The following adjustments and repairs can be made without removing
the steering differential from the vehicle:

23.1 Steering band adjustment

23.2 Steering band replacement

23.3 Slave cylinder replacement or repair

23.4 Drive axle assembly repair or replacement, including replacement
of oil seals, gaskets, bearings and the drive axle itself.

23.5 Drive axle housing repair or replacement, including replacement
of gaskets and drive axle housing itself.

24. INSTALLING STEERING BANDS:

24.1 Remove the grid plate over the drive unit.

24.2 Disconnect hydraulic hoses from slave cylinders.

- 24.3 Remove steering band adjusting nuts.
- 24.4 Remove drive unit case lid.
- 24.5 Remove spacer, spring and brake band rod assemblies.
- 24.6 Remove steering band anchor links.
- 24.7 Remove old steering bands.
- 24.8 Install new steering bands.
- 24.9 Install anchor links.
- 24.10 Install spacer, spring and brake band rod assemblies.
- 24.11 Install steering band adjusting nuts.
- 24.12 Install new drive unit case lid gasket.
- 24.13 Install drive unit case lid.
- 24.14 Connect hydraulic hoses to slave cylinders.

25. STEERING BAND ADJUSTMENT:

Tighten steering band adjusting nuts to 200 inch lbs., then back the nut off $1\frac{1}{2}$ revolutions.

CAUTION: DO NOT OPERATE THE VEHICLE WITH EXCESSIVE STEERING BAND DRAG. THIS WILL INDUCE HEAVY WEAR ON THE BRAKE LINING AND MAY CAUSE DIFFERENTIAL OVERHEATING. EXCESSIVE TORQUE WILL DAMAGE THE STEERING LINKAGE.

26. BLEEDING STEERING SYSTEM:

Remove the master cylinder cap and fill the cylinder with type SAE 70RI heavy-duty brake fluid. Replace cap to avoid contamination or loss of fluid during bleeding operation. Open the bleeder valves on slave cylinders located in the differential cover by turning valves $1/4$ to $1/2$ turn counter-clockwise. Slowly pull back steering levers, one at a time, to force fluid from the bleeder valves. While the levers are all the way back (in the position used to stop the vehicle), retighten bleeder valves. Repeat this operation until all air is removed from the system and the steering levers no longer feel "spongy".

CAUTION: DO NOT USE FLUIDS IN THIS SYSTEM WHICH DO NOT CONFORM TO SAE 70 RI SPECIFICATIONS. THEY WILL DAMAGE THE SEALS AND LOCK UP THE STEERING CONTROLS.

27. MAINTENANCE:

- 27.1 Drain and refill the drive unit case every 150 hours of operation and at the beginning of each operating season, if vehicle is only used seasonally.

Under normal operating conditions, check oil level weekly.
Under strenuous operating conditions, check oil level every 2 days.

- 27.2 Grease the drive axle bearings (through zerk fitting) about 3 - 4 pumps every 25 hours under normal operation. Use Conoco DN-600 grease or an all temperature grease conforming to MIL-G-10924A.
- 27.3 Keep steering bands adjusted (See Item 25 above)
- 27.4 Retorque drive sprocket bolts after 5 - 10 hours of initial operation.

28. TROUBLESHOOTING DIFFERENTIAL

SYMPTOM

POSSIBLE CAUSE

REMEDY

<p>Differential is overheating.</p>	<p>Steering bands are dragging. Driver is steering vehicle improperly. Low oil level. Bearing failure. Wrong oil in differential. Broken or chipped teeth on any of the differential gears. Slave cylinder malfunction.</p>	<p>Adjust steering bands. See procedure in "Common Adjustments and Repairs". Read and follow operating instruction for steering vehicle in owner's manual. Add oil to proper level and see "Differential is losing oil" section of Troubleshooting. Inspect all bearings. See procedure for "Checking Bearing Fit". Drain oil and replace with Conoco DN-600 or equivalent. Inspect all gears and replace as needed. Repair slave cylinders using proper kits ordered from Thiokol. Model 1200 part # is 1219237, kit # KT-1218-1. Model 2100 part # is 1209030, kit # KT-02-100-017.</p>
<p>Drive shaft turning, but vehicle doesn't move.</p>	<p>Failure in left or right hand drive train, or sheared gear teeth in the planetary gears, ring and pinion gears.</p>	<p>Pull steering levers, one at a time. If vehicle doesn't move when right lever is pulled but does move when left lever is pulled, failure is in the left-hand drive train. It could be a broken axle. If the vehicle doesn't move when the left lever is pulled but does move when the right lever is pulled, failure is in the right-hand drive train. If vehicle doesn't move when either lever is pulled, some gear teeth are probably sheared.</p>

SYMPTOM

POSSIBLE CAUSE

REMEDY

<p>Differential is losing oil.</p>	<p>Loose bolts on drive unit case lid. Loose bolts holding drive axle housings & bearing retainer to drive unit case. Drive unit breather port is leaking. Drive axle seal is leaking. Pinion seal is leaking. Cracked or broken axle housing or drive unit case.</p>	<p>Tighten bolts to proper torque. Tighten bolts to proper torque. Check weld around port for cracks or separations. Check inside of drive unit lid to make sure crimped end of breather port is open approximately 1/8 inch. Replace seal. Replace seal. Inspect and repair or replace as needed.</p>
<p>Differential is making unusual noise.</p>	<p>Bearing failure on pinion shaft. Chipped or broken gear teeth in ring or pinion gear, or drive unit planetary gears. Backlash has increased due to bearing or spacer failure in drive unit ass'y or pinion ass'y.</p>	<p>Replace bearings and see section on "Checking Bearing Fit". Disassemble, inspect all gears and replace broken gears. Replace worn parts and correct backlash to specification. See procedure for measuring backlash.</p>

SYMPTOM

POSSIBLE CAUSE

REMEDY

Steering is sluggish and unresponsive on Model 1200.	Brake fluid level is low in master cylinder. Master cylinder leaking. Hydraulic lines leaking. Air in hydraulic lines. Slave cylinders leaking.	Fill to proper level with SAE 70RI heavy-duty brake fluid. Rebuild master cylinder using kit number 1222036 ordered from Thiokol. Inspect lines. Replace leaking lines or faulty fittings. Bleed steering system. See procedure in "Common Adjustments and Repairs". Inspect slave cylinders. If they are leaking, repair kits can be ordered from Thiokol. Part number is 1219237, kit number KT-1218-1.
Steering levers rock back and forth noticeably during a turn.	Steering drums out of round.	Check steering drum face and edge runout with a dial indicator. Face runout should be no greater than .030 inch. Edge runout should be no greater than .060 inch.
Model 1200 will only turn in one direction.	Malfunctioning master cylinder or slave cylinder.	Inspect master cylinder and slave cylinders. Repair leaking cylinders Order repair kits from Thiokol. Slave cylinder part #1219237, kit #KT-1218-1. Master cylinder kit number 1222036.
Veers to the left or right on level ground when it should be travelling in a straight line.	Steering bands are out of adjustment.	Adjust steering bands. See procedure in "Common Adjustments and Repairs".

SYMPTOM

POSSIBLE CAUSE

REMEDY

Steering levers must be pumped to steer or stop vehicle.	Steering bands are out of adjustment. Air in hydraulic lines.	Adjust steering bands. See procedure in "Common Adjustments and Repairs". Bleed steering system. See procedure in "Common Adjustments and Repairs".
Steering requires more effort than normal.	Steering bands or steering drums are worn.	Replace worn steering bands. See procedure in "Common Adjustments and Repairs". If steering drums are badly grooved, they should be replaced. In an emergency, when the vehicle must be back in service before parts can arrive, steering drums can be machined a MAXIMUM OF .020 INCH. THIS IS ONLY AN EMERGENCY PROCEDURE AND IS NOT RECOMMENDED BY THYKOL. New drums should be ordered and installed upon arrival.
No steering response at all. No resistance at all on steering levers.	Broken steering linkage.	Inspect linkage. Repair or replace.

SECTION 5, BRAKE ASSEMBLY

1. MAINTENANCE:

See Fig. 19

- 1.1 Before driving the vehicle always check to see if the cable is tight enough to actuate the brake properly. Adjust as needed. (See Item 3 below).
- 1.2 Grease the brake arms after every 50 hours of operation. Zerks are at either end of the shaft on the mount bracket. Don't allow any grease to get on the disc!
- 1.3 Reset the clearance on the brake pads to .030" each time the brake arms are greased. (See Item 2 below).
- 1.4 Periodically clean and lubricate the brake cable.

2. ADJUSTING PAD CLEARANCE:

See Fig. 19

- 2.1 Release the hand brake. There should be enough slack so that there is a small gap (about 1/16") between the rear brake assembly cross-member and the nut and spacer on the end of the cable; also the brake arms should be contacting the set screws.
- 2.2 On each arm, loosen the locknut on the set screw, insert a feeler gauge set to .030" between the pad and the disc, and turn the set screw until a clearance of .030" is obtained. Then tighten the locknut.
- 2.3 Adjust the cable tension. (See Item 3.1 below)

3. ADJUSTING THE CABLE:

See Fig. 19

- 3.1 Since the brake cable will stretch, it should be constantly tightened to maintain the correct operating tension.

As the brake cable stretches it is tightened by turning the knurled cap on the top of the hand brake lever in a clockwise direction. The cable is correctly tightened when a force of 60 lbs., applied at the juncture of the knurled cap and hand grip, is required to lock the brake in the "on" (up) position.

The take-up distance on the hand brake will, however, be used up eventually. When this happens the cable must be reset.

3.2 To reset the cable:

See Fig. 19

- 3.2.1 Turn the knurled cap on top of the hand brake lever in a counter-clockwise direction until the cable adjustment is loosened all the way and the cap will turn no further.
- 3.2.2 Tighten the nut on the end of the cable at the rear brake crossmember until it is quite tight, then back off until there is about 1/16" space between the rear crossmember and the nut and spacer.
- 3.2.3 Adjust the pad clearance as described above in Item 2.
- 3.2.4 At some point the cable may stretch enough so that it cannot be made sufficiently tight to operate the brake.

When this occurs, replace the spacer between the rear brake crossmember and the nut with a longer spacer. Then reset cable as above.

4. REMOVAL OF DISC BRAKE ASSEMBLY:

See Fig. 19

- 4.1 Remove the nut, 2 washers and spacer from the brake cable at the rear brake assembly cross member.
- 4.2 Remove the nut and bolt at the top of each brake arm and remove the two crossmembers.
- 4.3 Remove the 2 nuts and washers on the brake arm shaft on the mount bracket and remove the 4 brake arms.
- 4.4 Remove the 4 bolts, nuts, and washers holding the disc to the flange yoke and remove the disc.
- 4.5 Remove the 1 1/2" elastic stop nut from inside the flange yoke and remove the flange yoke.
- 4.6 Remove the 4 bolts, nuts, and washers holding the mount bracket to the speedometer housing and remove the bracket.

5. INSTALLATION OF DISC BRAKE ASSEMBLY:

See Fig. 19

Installation is the reverse of the above removal procedure plus these steps:

- 5.1 Before installing the brake assembly, install the pads and retainers on the brake arms.

- 5.2 Torque the elastic stop nut in the flange yoke to 80 ft./lbs.
- 5.3 After the assembly is installed, adjust the pad clearance (See Item 2 above), reset the cable (See Item 3 above), and grease the brake arm shaft on the mount bracket.

6. BRAKE PAD REMOVAL

See Fig. 19

- 6.1 Remove the nut, 2 washers, and spacer from the brake cable at the rear brake assembly cross-member.
- 6.2 Locate the pad to be replaced and loosen the lock nut on that arm. Pin the locknut on its companion arm.
- 6.3 Back the set screws out on the pair of arms as far as possible short of removal. This allows the arms to lean out from the disc giving enough clearance to remove pad.
- 6.4 Remove the nut and bolt holding the affected retainers and pad assembly to the arm, then slide the retainers and pad assembly up along the brake arm and out.
- 6.5 Using Allen wrench, remove retainers from pad. NOTE: If replacement part is a unit, with the retainers welded to the pad, disregard step 6.5.

7. BRAKE PAD INSTALLATION

See Fig. 19

Reverse the above removal procedure adding these steps:

- 7.1 Adjust the pad clearance as described in Item 2 above, this section.
- 7.2 Adjust the cable as described in Item 3 above, this section.

FIG. 19, DRIVELINE BRAKE ASSEMBLY

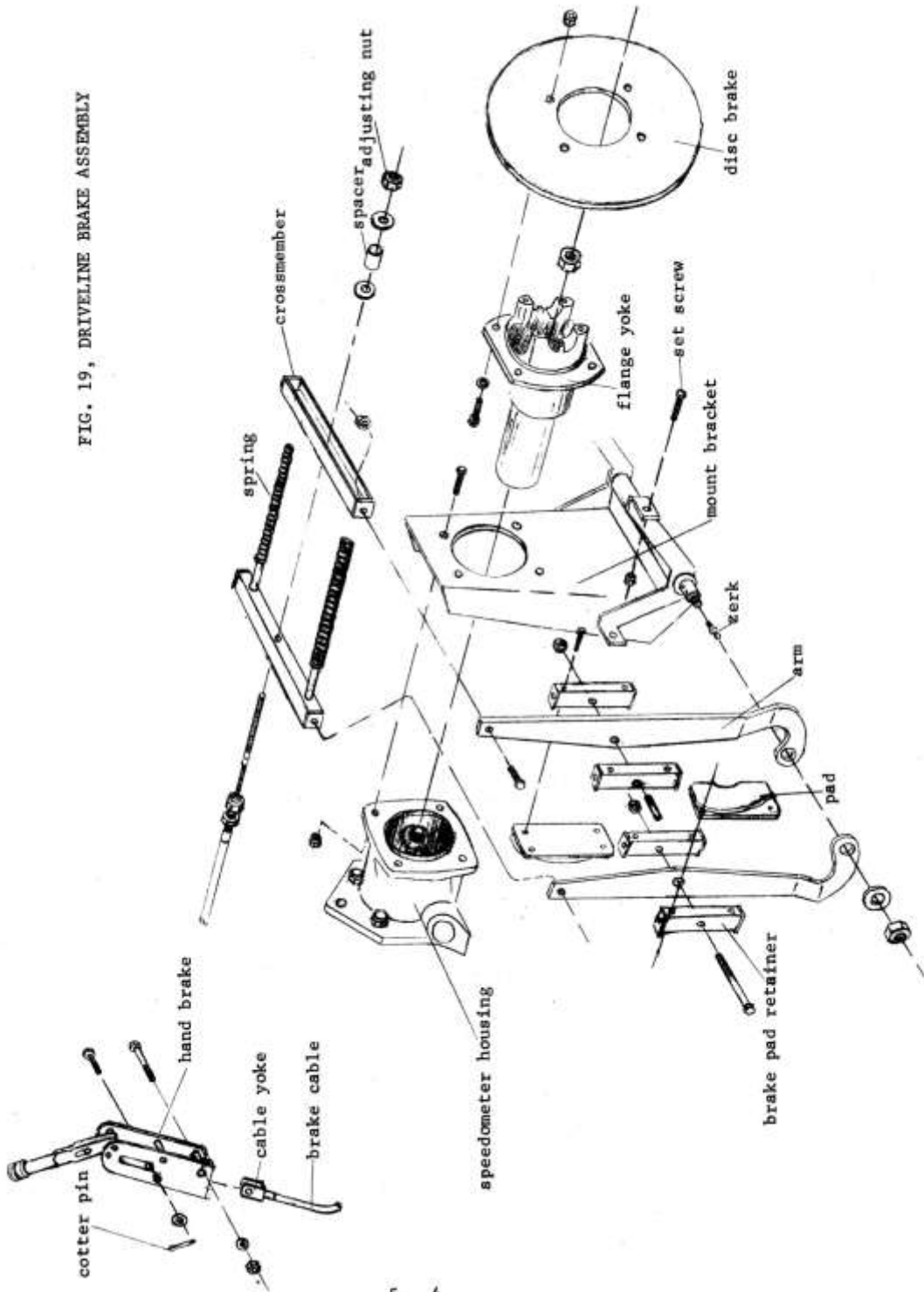

SECTION 6, TRANSMISSION

PART 6-1, LINKAGE:

1. GENERAL:

Check the transmission control head and make sure that when the control head lever is in drive position that the transmission shift lever is in full detent position. The control head shift gate must not be in such a relationship to the transmission shift lever that when you pull the control lever against the gate stop, it pulls the transmission lever partly out of full detent. Adjust the linkage if necessary to meet these conditions. (See Item 4 below).

2. REMOVAL OF SHIFT CABLE:

See Fig. 20

- 2.1 Make sure engine is stopped and the vehicle will not move.
- 2.2 Remove the 5 screws and remove the engine compartment plate on the driver's side of the engine compartment.
- 2.3 Remove the 6 screws holding the control head to the top of the engine compartment.
- 2.4 Lift the control head assembly out and unscrew the nut holding the ball joint to the control head pivot plate and remove the ball joint.
- 2.5 Remove the "U" bolt holding the cable to the control head assembly.
- 2.6 Remove the 6 screws from the cover on the lower chassis by the transmission shift lever and remove the cover.
- 2.7 Reach inside and forward at the opening created by step 2.6 above and remove the "U" bolt holding the cable to the transmission housing.
- 2.8 Snap the ball joint off the transmission shift lever, and pull the cable out of the vehicle.

3. INSTALLATION OF SHIFT CABLE:

See Fig. 20

- 3.1 Make sure the engine is stopped and the vehicle will not move.
- 3.2 Before installing a new cable, position the control head ball joint about halfway on its threaded cable shaft, and the transmission shift ball joint about three quarters of the way down on its threaded cable shaft. Tighten the jam nut up against the transmission shift ball joint.

FIG. 20, TRANSMISSION LINKAGE

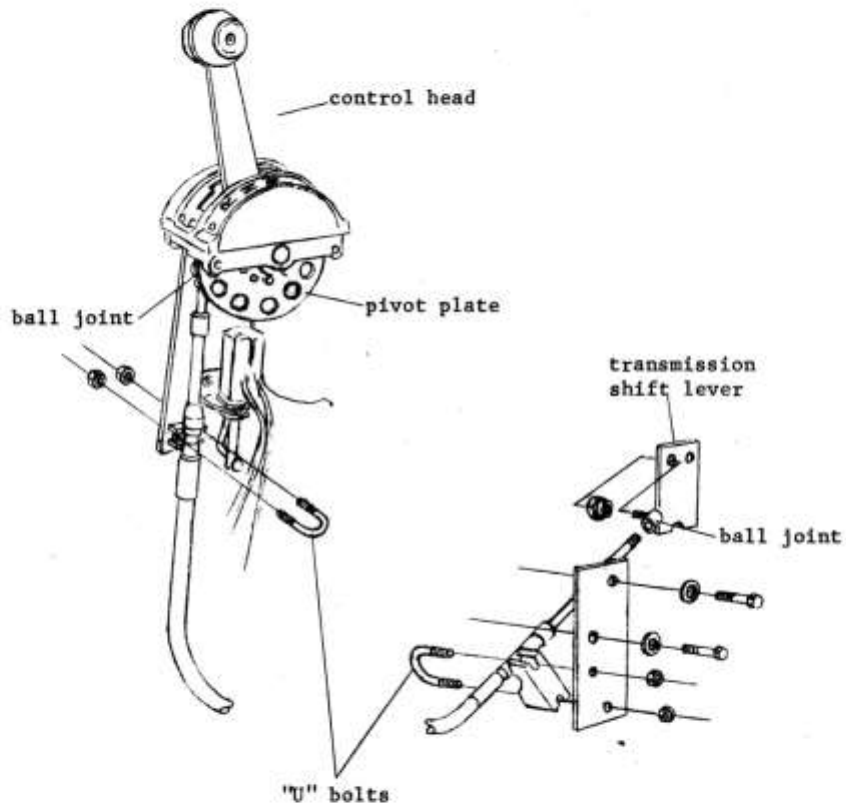

- 3.3 Thread the cable through the engine compartment from the control head under the motor mount back to the transmission.
- 3.4 Install the "U" bolts over the cable at the control head and on the transmission housing just forward of the transmission shift lever.
- 3.5 Snap the ball joint into place on the transmission shift lever, then loosely attach ball joint to pivot plate.
- 3.6 Adjust the cable using procedures described in Items 4.5-4.10 and NOTE below.
- 3.7 When adjustment procedure is done be sure to replace the plate on the lower chassis.

4. ADJUSTMENT OF SHIFT LINKAGE:

See Fig. 20

- 4.1 The shift cable is connected to the control head and to the transmission shift lever by 2 ball joints which screw onto either end of the cable. The ball joints then, can be positioned on the cable shafts by turning them clockwise or counter-clockwise, thus changing the length of the cable. They are locked into place by jam nuts.

Adjusting the cable therefore is a matter of moving these ball joints up or down the threaded cable shafts so that the cable length is right and the linkage operates correctly.

- 4.2 Make sure engine is stopped and the vehicle will not move.
- 4.3 Remove the 6 screws holding the control head to the top of the engine, then lift the control head assembly out until you can get to the ball joint.
- 4.4 Unscrew the nut holding the ball joint to the control head pivot plate and remove the ball joint. Then loosen the jam nut, freeing the ball joint.
- 4.5 Move the ball joint up or down the cable shaft the approximate distance needed to make the linkage operate correctly.
- 4.6 Insert the threaded end of the ball joint into the second hole (from the front of the control head) in the control head pivot plate and loosely attach the nut.
- 4.7 Push the control head assembly into position on top of the engine compartment, and holding it there, try shifting to see if linkage is operating correctly.

Linkage is right if the transmission shift lever is in full detent when the control head lever is in drive position and up against the gate stop (See Item 4.9 below).

- 4.8 If the linkage does not operate properly after this first trial, which is likely, since this is a trial and error procedure, repeat steps 4.3 through 4.7 (excepting 6 screws from control head are already removed, and jam nut is already loosened). Repeat as many times as necessary until the linkage does operate correctly.
- 4.9 When the linkage is right pull the control head assembly out and tighten the nut holding the ball joint to the pivot plate and tighten the jam nut up against the ball joint.
- 4.10 Push the control head assembly back into position on top of the engine compartment and install and tighten the 6 screws.

NOTE: IF THE LINKAGE CANNOT BE ADJUSTED BY THE ABOVE PROCEDURE THEN THE BALL JOINT AT THE TRANSMISSION SHIFT LEVER MUST ALSO BE MOVED. (See Items 2.6 and 2.8). WHEN THE ADJUSTMENT IS COMPLETED BE SURE AND TIGHTEN THE JAM NUT.

PART 6-2. TRANSMISSION:

1. REMOVAL:

- 1.1 The transmission must be removed with the engine. It cannot be removed by itself. (See SECTION I PART 1-3 for procedure.)
- 1.2 Once the engine and transmission unit is out, the transmission is removed from the engine as follows:
 - 1.2.1 Remove the access plate on the lower front transmission housing just forward of the flywheel.
 - 1.2.2 Reach in the opening created by step 1 and remove the bolts holding the torque converter to the flywheel. The transmission will have to be in neutral so the flywheel and converter can be turned to reach the bolts.
 - 1.2.3 Remove the bolts holding the transmission housing to the engine block.
 - 1.2.4 Supporting the transmission assembly, slide it back being careful to retain the torque converter in the transmission.

2. INSTALLATION:

- 2.1 The transmission should be installed with the engine. (See SECTION 1, PART 1-3 for procedure)
- 2.2 To assemble the transmission to the engine prior to installing engine-transmission unit into vehicle, reverse procedure 1.2 above.

3. MAINTENANCE:

3.1 General:

Severe damage to the automatic transmission is likely if improper manual shifting occurs during the vehicle's operation. Care must

be exercised to make sure that the transmission shift lever is in full detent at each position when the control head shift lever is moved to its corresponding stop. If you shift carefully, you can feel the transmission shift lever hit each detent as you move the control head lever.

Do not shift from second to third under full engine power; back off on the throttle, and allow the transmission to shift fully before applying full throttle or damage will result in about fifty per cent of the shifts made. This is due to slightly missing the detent position.

Do not shift from forward to reverse or from reverse to forward if the vehicle is moving or damage will result to the clutches.

Failure of the transmission can result from overheating the transmission under stall condition. It is possible to burn it up in seven to ten seconds of full stall operation.

WARRANTY POLICY-IMPORTANT:

1. We have been notified by Ford Motor Company that transmissions failed by improper shifting will not be covered by warranty since these are due to driver's errors. They will cover under warranty only those units which have been improperly assembled.
2. Failing park positions in these transmissions will not be covered under warranty. Shifting these vehicles into park position at 1 mph is equal to shifting an automobile into park at 15 to 20 mph and with exactly the same results, "broken park linkage rod." This failure is classified as driver error.

This transmission fluid system is not filtered. If the fluid is burned or contaminated, the whole system (transmission, converter, and cooler) should be drained and refilled with new Ford Type F automatic transmission fluid.

NOTE: BLACK OR BURNED OIL INDICATES DAMAGE TO THE CLUTCH PACK.

The transmission pan has been modified by a boxlike extension of its bottom called a deep sump. This sump is there to insure an adequate supply of fluid on steep grades. The pan also has a heating unit and thermostat as part of the winterization kit. (See section 15)

3.2 DRAIN & REFILL PROCEDURE:

- 3.2.1 Make sure the engine is stopped and the vehicle cannot move.
- 3.2.2 Remove the transmission pan plug located on the bottom of the sump.

- 3.2.3 Remove the cover on the lower front transmission housing. This will expose a part of the flywheel and torque converter. With the transmission in neutral move the flywheel and converter until you find a small plug in the converter. Remove this plug and drain the converter.
- 3.2.4 Loosen the hose clamps and remove the two transmission cooler hoses from the housing. Allow cooler and hoses to drain.
- 3.2.5 When the system is drained, replace the two cooler hoses to the transmission housing and tighten the clamps, replace the transmission pan plug, replace the converter plug, and finally, replace the cover on the lower front transmission housing.
- 3.2.6 Fill the transmission with Ford Type F automatic transmission fluid through the dipstick tube. Run the engine a minute or so and then fill the transmission again. With the transmission in P check the fluid level. Keep filling until the dipstick registers the proper amount. (See GENERAL TRANSMISSION SERVICE, front of this manual.)

SECTION 7, TRACK ASSEMBLY

PART 7-1, CLEAT REPLACEMENT:

See Fig. 21

When replacing a cleat, stop the vehicle and shut the engine off with the cleat to be replaced at the front or the back of the vehicle. If the cleat were in the middle, you would have great difficulty in reaching the bolts and backing plates on the side of the track next to the vehicle.

Remove and install as shown in Fig. 21.

PART 7-2, LACING REPLACEMENT:

See Fig. 21

To replace lacing it should be disconnected as described in PART 7-4 below. (Except, of course, the vehicle is not taken off the tracks.)

Remove and install as shown in Fig. 21

PART 7-3, BELT REPLACEMENT:

See Fig. 21

Except for the outside belt, replacement of a belt or belts is best done with the track off the vehicle. (See PART 7-4, this Section). Belt replacement is simply a matter of removing all bolts, backing plates and lacings along the damaged belt, removing the belt, then putting new belt in place and reinstalling all bolts, backing plates, and lacings. Torque lacing cleat bolts to 20 - 25 ft. lbs. and cleat bolts to 25 - 30 ft. lbs.

PART 7-4, TRACK INSTALLATION & REMOVAL:

1. REMOVAL:

See Figs. 21 & 22

- 1.1 Since this vehicle has no steering or braking capabilities without the tracks, this operation should take place on level ground so that once the vehicle is off the tracks, it won't roll away.

If a level place just isn't available, some provision must be made to immobilize the vehicle once it is off the tracks.

- 1.2 Drive the vehicle forward or backward and stop when the lacing is positioned over the front tire with the lacing bolts just below the lower chassis. Turn the engine off.
- 1.3 Remove the 4 nuts from the lacing bolts.
- 1.4 Grip the inside lacing bolt head (the one closest to chassis) with a

FIG. 21, TRACK ASSEMBLY

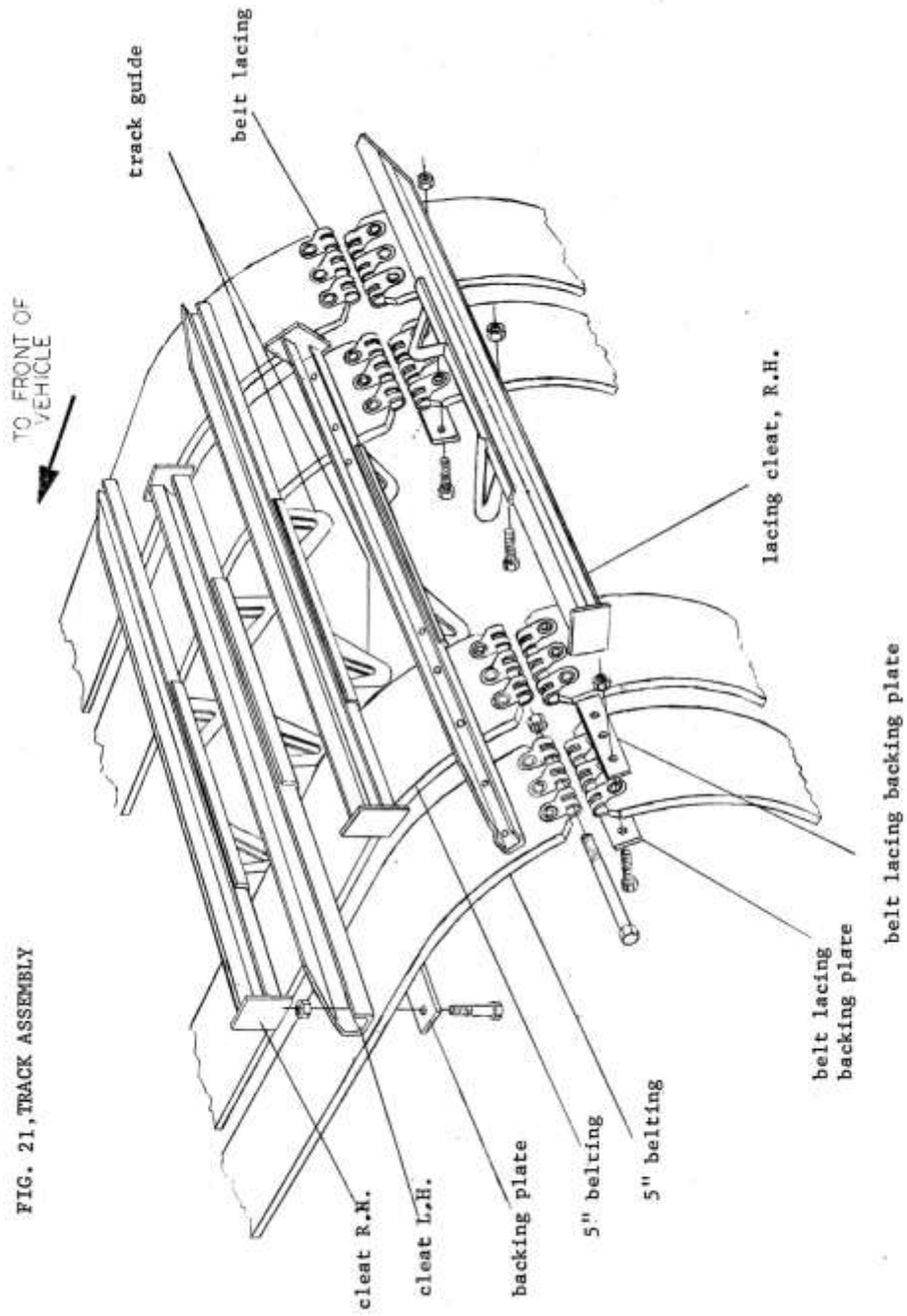

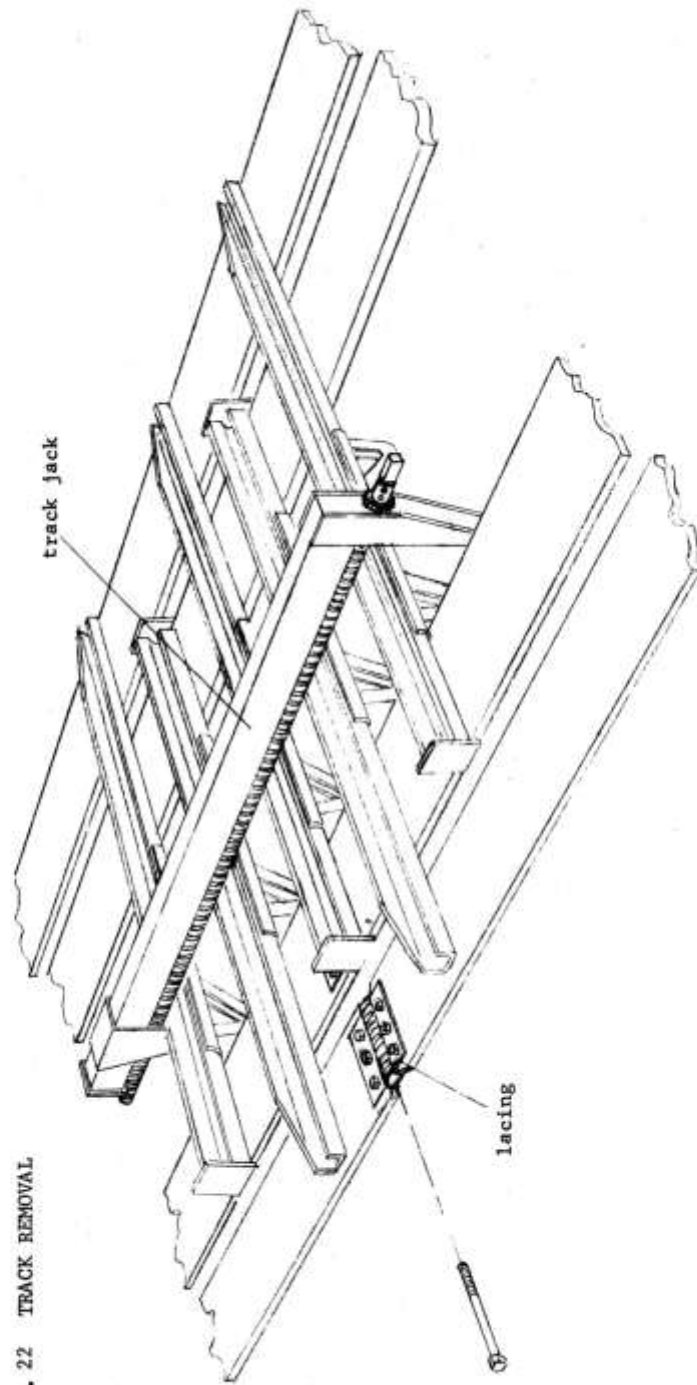

FIG. 22 TRACK REMOVAL

pair of pliers or vise grips and tap the bolt out by tapping on the pliers.

- 1.5 Back the vehicle until the lacing is over and between the second and third wheel from the front of the vehicle, then stop vehicle and shut the engine off.
- 1.6 Remove the grease zerks on the lower frame between the second and third wheels from the front of the vehicle, both sides. This allows pressure to bleed from the sliding member and allows the member to recede, thus giving enough slack for the removal operation.
- 1.7 Place a track jack on top of the track over and at a right angle to the lacing, so that the jaws of the track jack are in a position to contact the first or second cleats from either side of the lacing. The track jack should be positioned about in the middle of the track so it won't interfere when removing the bolts from the lacing.
- 1.8 Tighten the track jack enough so that there is enough slack to remove the lacing bolts easily.
- 1.9 Remove the remaining 3 bolts from the lacing.
- 1.10 Remove the track jack and lay both ends of the track flat on the ground.
- 1.11 Start the engine, pull the steering lever controlling the still tracked side all the way back, and drive the vehicle off the laid-out track.
- 1.12 If necessary, repeat steps 1.2 through 1.11 for other track and note the following:
 - 1.12.1 Remember that with one track off, power is only going to the tracked side. Thus, in order to drive the vehicle forward and back, as is necessary during that track's removal, pull the steering lever controlling the remaining track all the way back.
 - 1.12.2 When removing a track with the other side of the vehicle already untracked don't lay the entire track out when it is unlaced (as above). Instead, just lay the front section out, leaving the back section over the wheels and sprocket. Then, with someone holding tension on the track and guiding it, back the vehicle until the track runs out. (Remember to pull the steering lever controlling that side as described in Item 1.12.1 above.)

When track is run out push the vehicle the remaining distance off the track.

2. INSTALLATION:

2.1 PRIOR TO INSTALLATION:

See Fig. 23

2.1.1 Lay the tracks flat on the ground side by side with one track half a length ahead of the other, directly in front of the vehicle, and extending straight out in line with the wheels on each side. Make sure the cleats are properly directed so that they will engage the ground surface correctly.

2.1.2 Line up the row of track guides on each track with the wheels on either side by sighting from the end of each track.

2.1.3 Remove the grease zerks on the lower frame between the second and third wheels from the front of the vehicle, both sides. This procedure will allow pressure to bleed from the sliding member. As the pressure bleeds off the member will recede, thus giving enough slack for the removal operation.

FIG. 23

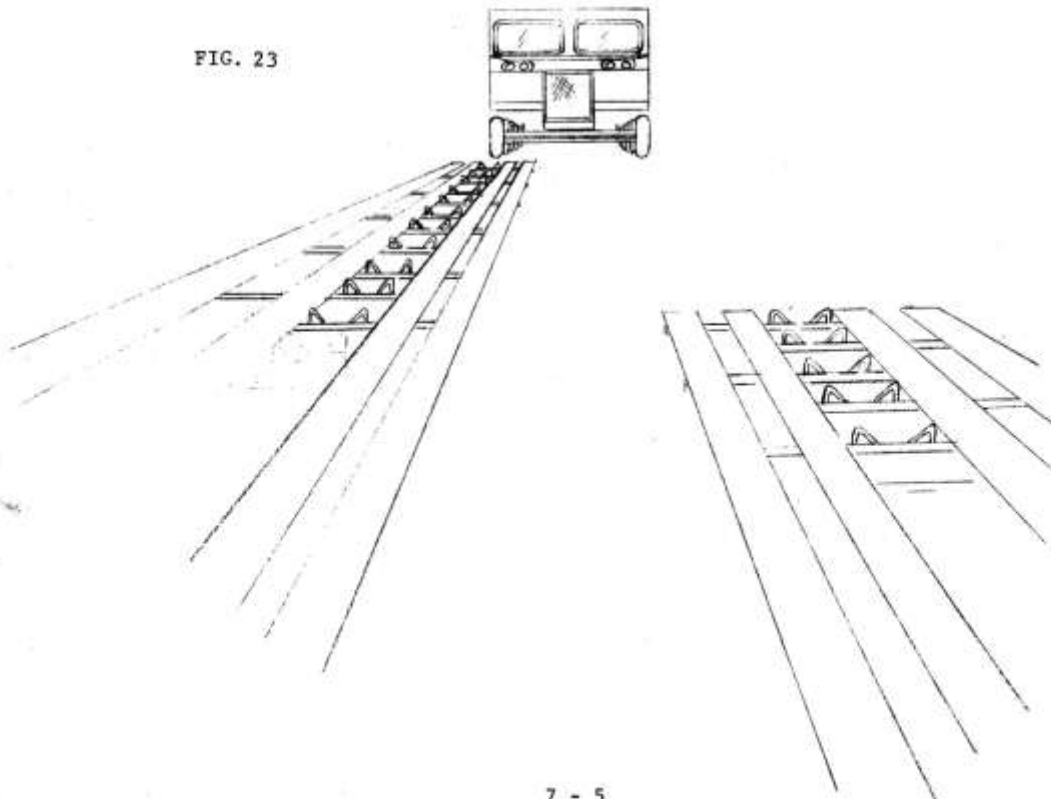

2.2 INSTALLATION OF TRACKS:

- 2.2.1 Roll the vehicle onto the closest track until just enough track extends beyond the back of the vehicle to be picked up and over the top of the sprocket. Now, place the track over the sprocket, making sure that it is properly engaged with no slack.
- 2.2.2 At this point start the engine and drive the vehicle forward. This will pull the first track on over the wheels and also place the vehicle onto the second track. Pull the steering lever controlling that side all the way back, (See Item 1.12.2 above.) Watch the track carefully though, because the sprocket has a tendency to jam the track down between itself and the rear wheel. It will be helpful if a second man could guide the track over the wheels. Stop the vehicle when the lacing on the first track rests on the second wheel from the front. Pick the remaining end of the first track up and over the front wheel and connect the lacings as described below in Item 2.3.
- 2.2.3 Now check the remaining track, if just enough extends beyond the rear sprocket to pick up and over, fine. If not, the vehicle will have to be driven backward or forward. When vehicle and track are in the proper position, place the second track over the top of the sprocket.

2.2.4 Repeat step 2.2.2 above.

2.3 PROCEDURE FOR CONNECTING THE LACINGS:

- 2.3.1 Select the track to be laced first, then place a track jack over and at right angles to the lacing and clamp the first cleats from either side of the lacing. The jack should be situated on one side of the track guide. Now tighten the jack. (See figure 24a; also figure 20).
- 2.3.2 Set another jack over and at right angles to the lacing and clamp the second cleats from either side of the lacing. Now tighten the second jack until the first jack becomes loose. (See Figure 24 b.)
- 2.3.3 Remove the first jack, and keeping it on the same side of the track guide as before, reposition it so that it too clamps the second cleats. There should now be two jacks, one on either side of the track guide and each clamping the second cleats. (See figure 24c)
- 2.3.4 Tighten both jacks back and forth until the lacing meets and meshes. (See figure 24d.)
- 2.3.5 Insert the 3 bolts through the lacing and apply locking nuts. Do not tighten the bolts all the way, because the lacing must move freely.
- 2.3.6 Remove the track jacks.

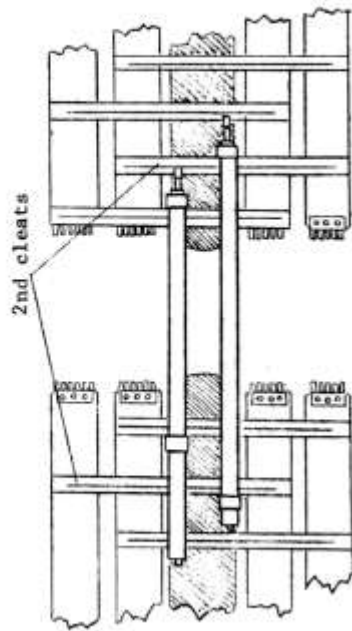

FIG 24 B

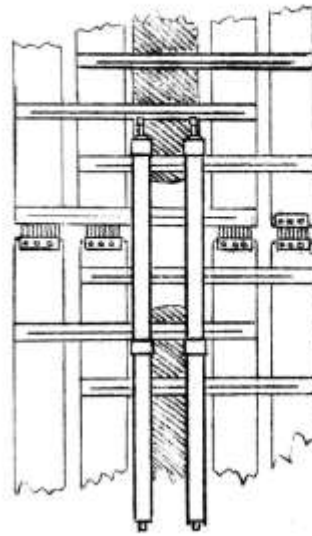

FIG 24 D

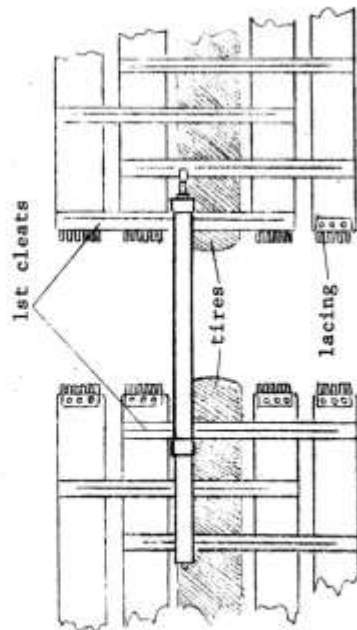

FIG 24 A

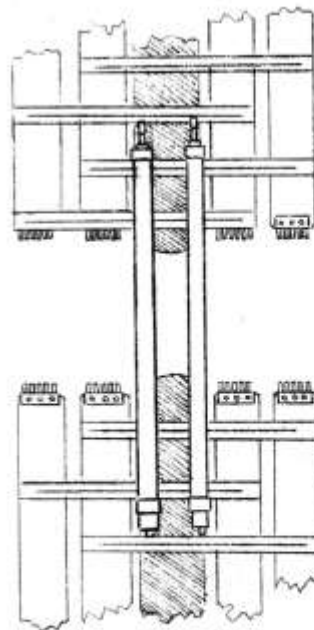

FIG 24 C

- 2.3.7 Drive the vehicle forward and stop when the lacing bolts drop just below the lower chassis up front. Turn the engine off.
- 2.3.8 Install the remaining bolt and nut in the lacing. (Track jack may have to be used)

2.4 TIGHTENING THE TRACKS:

- 2.4.1 Replace the zerks on the lower frame between the second and third wheels from the front of the vehicle.
- 2.4.2 To tighten a track, place a grease gun onto the zerk on that side and pump. The operation of the grease gun will push the sliding member forward and take up the excess slack. When the desired tension is reached, stop pumping. Use Conoco DN-600 grease or an all temperature grease conforming to MIL-G-10924A.
- 2.4.3 The tracks should be tightened equally and only enough to eliminate jumping of the tracks on the drive sprocket.

Also it will be necessary, due to the stretching of the belt material, to readjust the track tension after the first few hours of operation.

See Item 3 below.

3. TRACK TENSION:

Track tension is not critical on this vehicle. Running with the tracks excessively tight will reduce power and consume excess fuel due to increased rolling resistance. The tracks should be tightened, only enough to eliminate excessive jumping or slippage of the tracks on the drive sprockets. Occasional jumping of one tooth between the track and sprocket is normal. This happens most often in tight turning conditions. It will be necessary to readjust track tension after the first few hours of operation due to an initial stretch of the track belting. In addition, after 50 hours of operation, track bolts should be retightened to the following torque specifications: lacing cleat bolts - 20 to 25 ft. lbs., cleat bolts - 25 to 30 ft. lbs.

It is difficult to give an exact setting for track tension because this varies somewhat with the temperature and environment in which the vehicle is operated. As a guide, the upper portion of the track should sag approximately 1/4 inch between adjacent wheels (sag between sprocket and rear wheel will be higher). Make this check only after driving the vehicle a few hundred yards and allowing it to coast to a stop.

The only time it has been found necessary to run the tracks with more tension than described above is in severe terrain where muskeg, rocks and stumps are encountered during turning operations. In these conditions, the tracks should be tightened until the upper portion of the track has little or no sag. After tightening the tracks, the vehicle should be driven a short distance. If the track tensions are

unequal, the vehicle will tend to drift or veer slightly toward the side having the tighter track. Equalizing the tension will improve the directional stability of the vehicle and make it more pleasant to drive on long trips.

For long, cross-country runs where a minimum of turning and maneuvering is expected, a saving in gasoline and relief from track abuse can be gained by adjusting the track more loosely than normal.

4. DO'S AND DON'TS:

You run the risk of losing a track if you drive a vehicle into an area where the terrain is so uneven it causes the vehicle's tracks to become canted at sharp angles to the vehicle's body. A deeply-rutted dirt road may cause such a condition. A track partially in and out of a deep rut is tilted sharply out of its normally perpendicular relationship with the drive sprocket and wheels. When this occurs, you can literally drive the track right off the vehicle.

If a track begins to come off while driving the vehicle up or down a slope in a canted position, stop the vehicle immediately. Before attempting to reposition the track, anchor the vehicle. If you lose a track going uphill or down hill, you will lose braking ability unless you pull both steering levers.

If the track has derailed to the inside of the tires rather than to the outside, it should be inspected to make sure it hasn't jammed before an attempt is made to move the vehicle. Attempting to move a vehicle with a jammed track may snap the track belting or even the drive axle. If the track is jammed and cannot be freed, it will have to be removed from the vehicle and repositioned manually. A tow vehicle or an anchored winch will be useful whenever a track has come completely off or must be removed from a vehicle.

1
2
3
4
5
6
7
8
9
10
11
12
13
14
15
16
17
18
19
20
21
22
23
24
25
26
27
28
29
30
31
32
33
34
35
36
37
38
39
40
41
42
43
44
45
46
47
48
49
50
51
52
53
54
55
56
57
58
59
60
61
62
63
64
65
66
67
68
69
70
71
72
73
74
75
76
77
78
79
80
81
82
83
84
85
86
87
88
89
90
91
92
93
94
95
96
97
98
99
100

1
2
3
4
5
6
7
8
9
10
11
12
13
14
15
16
17
18
19
20
21
22
23
24
25
26
27
28
29
30
31
32
33
34
35
36
37
38
39
40
41
42
43
44
45
46
47
48
49
50
51
52
53
54
55
56
57
58
59
60
61
62
63
64
65
66
67
68
69
70
71
72
73
74
75
76
77
78
79
80
81
82
83
84
85
86
87
88
89
90
91
92
93
94
95
96
97
98
99
100

1
2
3
4
5
6
7
8
9
10
11
12
13
14
15
16
17
18
19
20
21
22
23
24
25
26
27
28
29
30
31
32
33
34
35
36
37
38
39
40
41
42
43
44
45
46
47
48
49
50
51
52
53
54
55
56
57
58
59
60
61
62
63
64
65
66
67
68
69
70
71
72
73
74
75
76
77
78
79
80
81
82
83
84
85
86
87
88
89
90
91
92
93
94
95
96
97
98
99
100

SECTION 8, SUSPENSION SYSTEM

PART 8-1, WHEEL CHANGING PROCEDURES:

1. GENERAL:

The tires on this vehicle are foam filled and cannot be changed like conventional tires, therefore replace wheels and tires as units.

You can remove the second, third, fourth, and fifth wheels from the front with the tracks still on. The front wheels should not be removed, however, unless the tracks are disconnected and lifted away, or the vehicle is in an untracked state.

2. WHEEL CHANGING PROCEDURE WITH TRACKS OFF:

2.1 Jacking up the wheel:

See Fig. 25

2.1.1 It is rarely necessary to jack the entire vehicle up to change a wheel, instead the torsion arm is utilized and only the wheel is raised.

2.1.2 To raise the wheel, place a suitable jack on the ground just in back of the wheel and under the torsion arm. As the jack is extended, it will contact the torsion arm and raise the wheel.

NOTE: If the vehicle should have to be raised, the jack or jacks should be placed under the lower frame or lower chassis.

FIG. 25

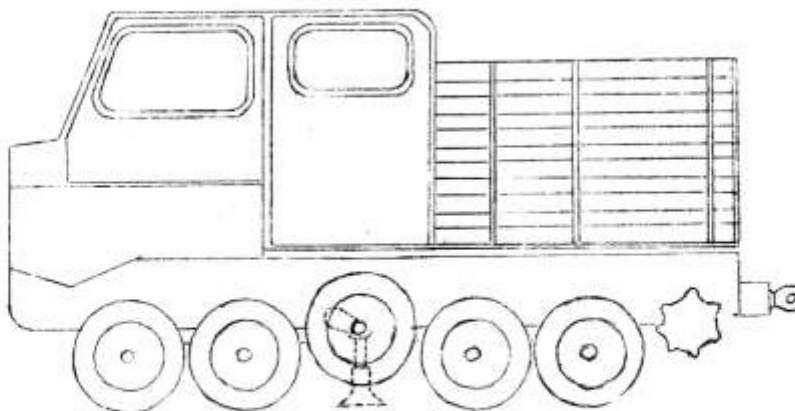

2.2 Removing the wheel:

See Fig. 26

- 2.2.1 Pry the grease cap off with a screwdriver or a suitable pry bar.
- 2.2.2 Remove the cotter pin.
- 2.2.3 Remove the slotted nut.
- 2.2.4 Remove the washer.
- 2.2.5 Remove the outer cone, keeping it out of the dirt.
 - 2.2.5.1 This can be done by pulling the wheel out a little then gently pushing it back. This should force the cone out far enough to be grasped and pulled off.
 - 2.2.5.2 Should 2.2.5.1 not be effective, the outer cone will have to be pried or punched out after the wheel is taken off.
- 2.2.6 Pull the wheel off.
- 2.2.7 Insert a drift, a bar, a piece of pipe, or some suitable blunt tool through the wheel hub and lightly tap the inner cone and grease seal out. Keep the cone and seal clear of the dirt.
- 2.2.8 Check the seal and both cones; if they are worn, replace them, if not reuse them. Cups (bearing races) should be no problem, they are already pressed into the new wheel by the manufacturer.

2.3 Putting on new wheel:

See Fig. 26

NOTE: If the new wheel does not have bearing cups, install new ones or use the old ones if they are good:

Remove the old cups by tapping on a drift or other suitable blunt tool inserted through the wheel hub and contacting the edge of the cup. The cup fits tightly, so one side of the cup will have to be tapped and then the other, and the process repeated until the cup pops out.

Cups are installed much the same way as above except they are tapped in and not out.

FIG. 26, WHEEL AND AXLE ASSEMBLY

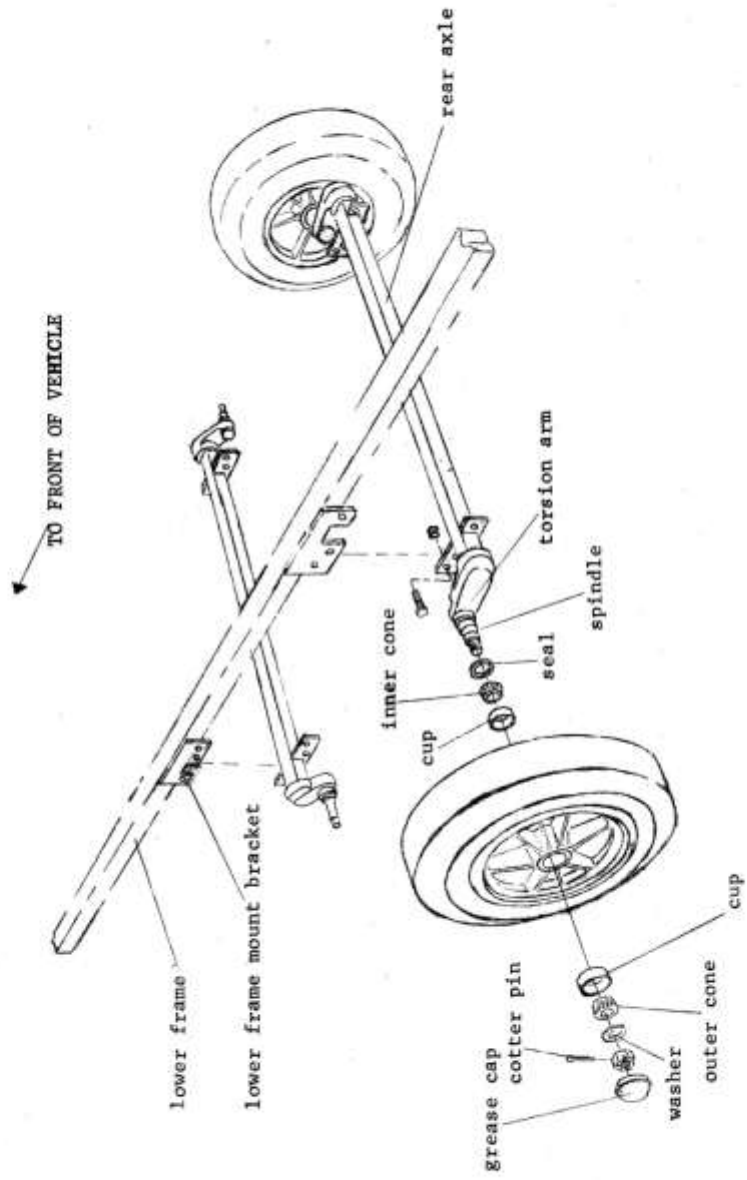

- 2.3.1 Insert the inner cone into the wheel hub on the wheel's inner side.
- 2.3.2 Insert the grease seal over the inner cone and tap it into place by hammering on a flat piece of steel or a block of wood that has been placed over the seal. Do not tap directly on the seal.
- 2.3.3 Put the wheel on the spindle, rotating it slightly to seat the rubber ring in the grease seal.
- 2.3.4 Insert the outer cone.
- 2.3.5 Place the washer over the outer cone.
 - 2.3.6.1 Screw the nut down until the cones are fairly tight, and the wheel turns with some difficulty.
 - 2.3.6.2 Back the nut off until the wheel turns freely, no further.
 - 2.3.6.3 Turn the nut slightly one way or the other until the slot on the nut and the hole in the spindle are lined up. Better a little loose than too tight.
- 2.3.7 Insert and secure the cotter pin.
- 2.3.8 Install the grease cap.
- 2.3.9 Place a grease gun on the wheel zerk and pump until grease flows from the seal. Use Conoco DN-600 grease or an all temperature grease conforming to MIL-G-10924A.
- 2.3.10 Lower the wheel.
- 2.3.11 Remove the jack.

3. WHEEL CHANGING WITH TRACKS ON

Applies to all except front wheels, since they cannot be removed without unlacing the track and getting it out of the way. Note also that the special tool cannot be used on the front wheel.

See Item 4 below for front wheel changing procedure.

See Figs. 22, 27a & b, and 28.

- 3.1 Release the track tension on both sides by removing the grease zerks on the lower frame between the second and third wheels from the front of the vehicle. Place a track jack at full extension onto the track cleats and over the track guide and tighten it, thus pulling some slack into the track.

- 3.2 Use the special tool provided in kit to raise the wheel and spread the track. To use:
- 3.2.1 Crawl underneath vehicle with tool up to damaged wheel.
 - 3.2.2 Remove the hairpin and separate the axle cup from the spreader arm. Slip the axle cup over the lower end of the torsion arm with modified clevis pin pointing inside, toward the vehicle.
 - 3.2.3 Place the spreader arm onto the axle cup clevis pin and replace hairpin. The spreader arm should be slanted the same way as the torsion arm, with the rounded end of the arm to the top under the second belt from the inside, and the offset cleat fork to the bottom over a cleat and between the track guide and the second belt from the inside. (Note that all the torsion arms except the rear ones are trailing, with the rear ones pointing to the front) Cleat fork offset must face away from the vehicle, and the relieved portion of the spreader arm must face downward to torsion arm.
- NOTE: SINCE THE SPREADER ARM CAN BE PLACED ONLY ONE WAY RELATIVE TO THE TORSION ARMS, AND SINCE THE OFFSET CLEAT FORK MUST ALWAYS FACE AWAY FROM THE VEHICLE, THE CLEAT FORK WILL HAVE TO BE SWITCHED FROM ONE SIDE OF THE SPREADER ARM TO THE OTHER, DEPENDING UPON WHICH SIDE OF THE VEHICLE THE DAMAGED WHEEL IS FOUND.
- 3.2.4 With tool in place crawl out and drive the vehicle forward or backward and rotate the tool to a vertical position (forward for only the 5th wheels on either side, backward for the 2nd through 4th wheels on either side. --See below for front wheel changing procedure) thus raising the wheel and spreading the track.
- Procedure is as follows:
- 3.2.4.1 Start the vehicle and let it warm up so that it runs smoothly.
 - 3.2.4.2 Set the hand brake, put the vehicle in forward or reverse (depending on which wheel is being changed), and, without touching the accelerator pedal, let the hand brake off and let the vehicle creep to rotate tool into position. The steering lever that controls the side opposite the side the tool is being used on will have to be operated to counteract the vehicle's tendency to skew around.
- 3.3 Alternately, jack up the wheel by placing a small hydraulic jack on the track just in back of the wheel and under the torsion arm, and raise the wheel until it clears the bottom track guide.
- 3.4 Remove the wheel using the procedure described under Item 2.2 above,

FIG. 27a

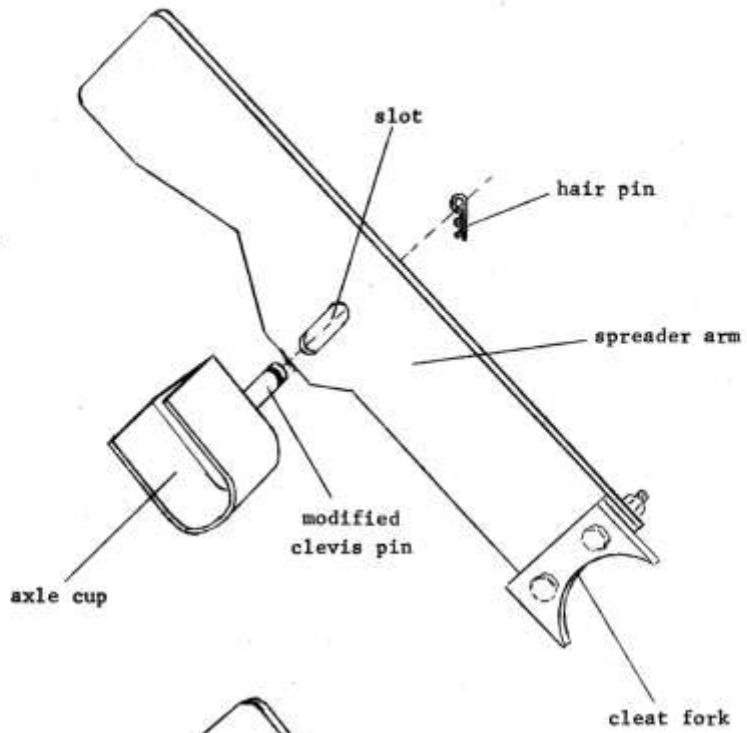

FIG. 27b

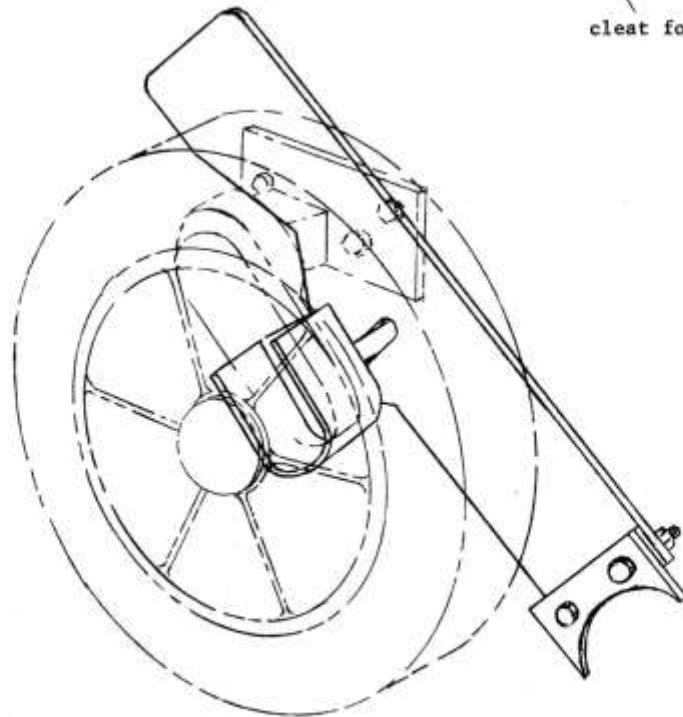
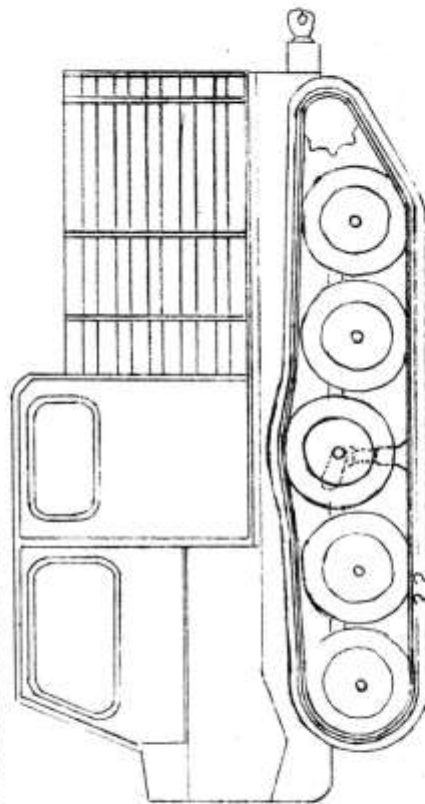

FIG. 28, USE OF HYDRAULIC JACK



except that if the special tool has not been used, the wheel has to be worked out from under the track guide, or someone could lift the track off the wheel momentarily while it is pulled, or the track could be raised clear of the wheel by a floor jack.

- 3.5 Install the new wheel using the procedure described under Item 2.3 above.
- 3.6 Drive the vehicle off the special tool by driving the vehicle in the opposite direction from the one used to engage the tool or, if you have used jacks, loosen and remove them.
- 3.7 Tighten the track:
 - 3.7.1 Replace the zerks on the lower frame.
 - 3.7.2 To tighten a track, place a grease gun onto the zerk on that side and pump. The operation of the gun will push the grease cylinder forward and take up the slack. Use Conoco DN-600 grease or an all temperature grease conforming to MIL-G-10924A.
 - 3.7.3 The tracks should be tightened equally and only enough to eliminate jumping of the tracks on the drive sprockets. See SECTION 7, PART 7-3, ITEM 3.

4. CHANGING FRONT WHEEL

- 4.1 Unlace the track on the side of the front wheel to be changed, laying the bottom part of the track out in front on the ground, and rolling the top part of the track back out of the way. See SECTION 7, PART 7-4.
- 4.2 Drive the vehicle forward until the front wheel is off the laid out track with the second wheel still on and stop.
- 4.3 At this point the front tire will be clear of the ground enough to change. Proceed as in Item 2.3 above.
- 4.4 Alternately you could proceed as above, except instead of driving forward until front wheel is off the track, use the special tool (See Item 3.2) to raise the second wheel from the front, which will also raise the first wheel enough to be changed. (Tool cannot be used on the front wheel)

Note that when the track is unlaced as above, the special tool will still function. The top track plays no part in the actual operation of the tool.

- 4.5 A third way to change the front wheel is to unlace the track as above, then use a hydraulic jack to raise the torsion arm. See Item 3.3

PART 8-2. AXLE REPLACEMENT PROCEDURES:

1. GENERAL:

The wheel spindles and torsion arms are not replaceable, they are part of the axle assembly. Thus, if a spindle is damaged or the spring fails or the axle is otherwise damaged, the entire axle assembly must be replaced.

Each axle assembly is bolted to the lower frame via a mounting bracket on either side. The two brackets on the axle assembly match up with two brackets on the frame and when bolted together form the only two points of contact between frame and axle.

Therefore, removing an axle assembly is accomplished by first removing the wheels and then removing the bolts from the mounting brackets on either side. Of course, to remove the front wheels, first remove the tracks (PART 8-1).

The mounting brackets are the same for all the axle assemblies except the front one. Here the bracket is somewhat different because the front axle assembly connects to the sliding member. However, removal is essentially the same; once the bolts are removed from the brackets the axle is free.

NOTE: The torsion arms on the back axle assembly point toward the front of the vehicle and not toward the back of the vehicle like the rest.

See Fig. 26

2. CHANGING AXLE ASSEMBLY WITH THE TRACKS OFF:

2.1 Removing axle assembly:

See Fig. 25 and 26

2.1.1 Remove both wheels from the axle assembly to be changed using the procedure given in PART 8-1, Item 2.

2.1.2 The axle assembly can now be removed by one man as follows:

2.1.1 Remove all the bolts except one from one of the brackets. Unscrew the nut on the remaining bolt until it is quite loose.

2.1.2 Go to the other side and remove all the bolts from the bracket. As that end becomes free, lower it to the ground.

2.1.2.3 Now, return to the first side and remove the remaining bolt. At this point, one of two things will happen: (1) The assembly will be freed and you can lower it to the ground or, (2) It will remain in position, jammed against the bracket. If this is the case, simply go around to the other side and raise that end of the assembly a little and the whole thing will drop free.

2.1.3 Alternately the axle assembly could be removed by two men, or you could put a floor jack underneath to support the assembly while the bolts were removed and then use the jack to lower it.

2.2 Installing axle assembly:

2.2.1 One man can install an axle assembly by reversing the procedure given above:

2.2.1.1 Place the assembly under the vehicle in correct position relative to mount brackets.

2.2.1.2 Raise one end to bracket and install one nut and bolt, loosely.

2.2.1.3 Raise the other end to bracket and install all nuts and bolts on that side.

2.2.1.4 Install the remaining nuts and bolts.

2.2.1.5 Tighten all bolts, both sides.

2.2.2 Alternately, of course, two men could install the axle assembly or a floor jack could be used to raise it to the brackets.

2.2.3 Install wheels using procedures given in PART 8-1, Item 2.

3. CHANGING AXLE ASSEMBLY WITH TRACKS ON:

See Fig. 26, 27 and 28

3.1 Removing axle assembly:

3.1.1 Remove both wheels from the axle assembly to be changed using the procedure given in PART 8-1, Item 3.

3.1.2 Remove axle assembly using procedures given in Item 2, above.

3.2 Installing axle assembly:

3.2.1 Install new axle assembly using procedure given in Item 2, above.

3.2.2 Install wheels using procedures given in PART 8-1, Item 3.

PART 8-3, TRACK ADJUSTMENT ASSEMBLY:

1. GENERAL:

The track adjustment assembly on this vehicle is fairly trouble free. About the only maintenance that is needed is to occasionally replace a hose, or the packing and washer on the piston.

2. REMOVAL:

See Fig. 29

2.1 Remove the zerk from the plate thru opening in frame.

2.2 Remove the 2 screws on either side of the zerk opening that hold the plate to the frame.

2.3 Remove the bolt, extending through frame and cylinder, located a few inches in front of the zerk opening.

2.4 Pull the sliding member and the attached track adjusting assembly out of the frame.

2.5 Drive out the pin holding the piston to the sliding member.

3. DISASSEMBLY:

See Fig. 29

3.1 Remove the snap ring from cylinder wall.

3.2 Pull piston out of cylinder and remove packing and washer from groove in piston.

3.3 Unscrew hose from cylinder, then from plate.

4. ASSEMBLY:

See Fig. 29

Reverse the above disassembly procedure.

5. INSTALLATION:

See Fig. 29

Reverse the above removal procedure.

FIG. 29, TRACK ADJUSTING ASSEMBLY

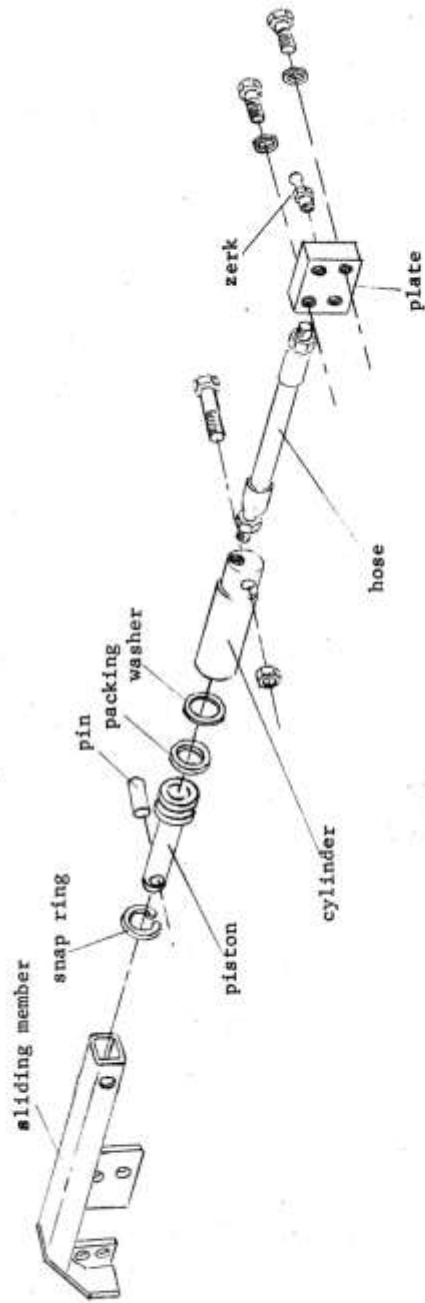

SECTION 9, COOLANT SYSTEM

PART 9-1, RADIATOR:

1. REMOVAL:

- 1.1 Turn the engine off and make sure the vehicle cannot move.
- 1.2 Remove the flat and curved plates under the radiator in front of the vehicle.
- 1.3 Open the radiator access door on the front of the cab and remove the radiator cap and pull the rubber overflow hose off the outlet on the radiator fill neck.

NOTE: WHEN REMOVING THE RADIATOR CAP USE CAUTION AND THE FOLLOWING PROCEDURE TO AVOID INJURY: WITH ENGINE OFF, PLACE A CLOTH OVER CAP AND TURN IT SLOWLY COUNTERCLOCKWISE TO THE FIRST DETENT AND LET THE PRESSURE BLEED OFF, THEN TURN CAP AGAIN COUNTERCLOCKWISE TO REMOVE IT.

- 1.4 Open the drain cock at the bottom of the radiator and allow the radiator to drain.
- 1.5 Remove the two access plates on either side of the engine compartment inside the cab.
- 1.6 Disconnect the hoses at the radiator. (The bottom hose can best be reached from underneath.)
- 1.7 Remove the lifting eye assembly on the front of the vehicle.
- 1.8 Remove the small grill in front of and covering the transmission cooler, then disconnect and plug the hoses, and also plug the transmission cooler.
- 1.9 Remove the 4 bolts mounting cab to the front of the lower chassis (2 on the front corners inside the cab, and 2 on either side of the engine compartment inside the cab.) This will allow the radiator assembly to slip out somewhat easier.
- 1.10 Remove the bolts holding radiator assembly to chassis.
- 1.11 Slide the radiator assembly down and out of the chassis.
- 1.12 Remove the 5 screws around the fan shroud (the screws hold the radiator too) and remove the fan shroud and the radiator from the mount bracket.

2. INSTALLATION:

Reverse the above removal procedure and add the following steps:

- 2.1 See Part 7 of Ford engine manual at the front of this booklet.
- 2.2 Refill the radiator. Coolant system capacity is approximately 20 quarts.

Use a ratio of 70% anti-freeze to 30% water - - this would be 14 quarts of anti-freeze to 6 quarts of water.

- 2.3 Check the transmission fluid level and fill as needed using procedure described in SECTION 6, PART 6-2.

3. MAINTENANCE:

See Part 7 of Ford engine manual at the front of this booklet and NOTE below.

NOTE: THE DRAIN PLUG ON THE PASSENGER SIDE OF THE ENGINE HAS BEEN REPLACED BY AN ELBOW JOINT AND HOSE TO PUMP UNIT WHICH IS PART OF THE COOLANT HEATING SYSTEM (WINTERIZATION KIT).

See Fig. 36, WINTERIZATION KIT

WHEN DRAINING SYSTEM, DISCONNECT THIS HOSE AT THE PUMP AND OPEN VALVE TO THE CAB HEATER (PULL OUT THE SILVER KNOB ON TOP OF THE ENGINE COMPARTMENT TO THE DRIVER'S SIDE OF CHOKE. THIS WILL NOT ONLY DRAIN THE BLOCK BUT WILL ALSO DRAIN THE COOLANT HEATING SYSTEM AND THE CAB HEATER.

PART 9-2, TRANSMISSION COOLER:

1. REMOVAL:

- 1.1 Remove the lifting eye assembly on the front of the vehicle.
- 1.2 Remove the small grill in front of and covering the transmission cooler.
- 1.3 Disconnect and plug the hoses, and also plug the transmission cooler.
- 1.4 Remove the 4 bolts (2 on each side) holding the transmission cooler to the radiator assembly bracket.
- 1.5 Remove the transmission cooler.

2. INSTALLATION:

Reverse the above removal procedure.

3. MAINTENANCE:

Drain the cooler as required - see SECTION 6, PART 6-3.

PART 9-3, HEATER:

1. REMOVAL:

- 1.1 Remove the instrument panel using the procedure described under SECTION 10.

- 1.2 Remove the 9 bolts holding the cab to the chassis and lift or prop the front of the cab up enough so that the heater can clear the ledge on the engine compartment.

See SECTION 13.

NOTE: WHEN CAB IS LIFTED OR PROPPED, MAKE SURE IT IS SECURE AND CAN'T FALL.

- 1.3 Open the radiator access door located on the front of the cab outside. Loosen the clamps and pull the two hoses off the heater, then remove the 4 screws holding the heater to the mount brackets.

- 1.4 Remove the heater.

2. INSTALLATION:

Reverse the above removal procedure.

PART 9-4. HEATER CONTROL

See Fig. 30

The heater control is next to the choke on the passenger side of the engine compartment cover and controls a valve on the heater hose.

Removal and Installation is very similar to that of the choke (See SECTION 2). The only difference being that instead of a screw stop to hold the inner cable to the valve, the inner cable is coiled and placed on a post on the valve.

FIG. 30, HEATER VALVE ASSEMBLY

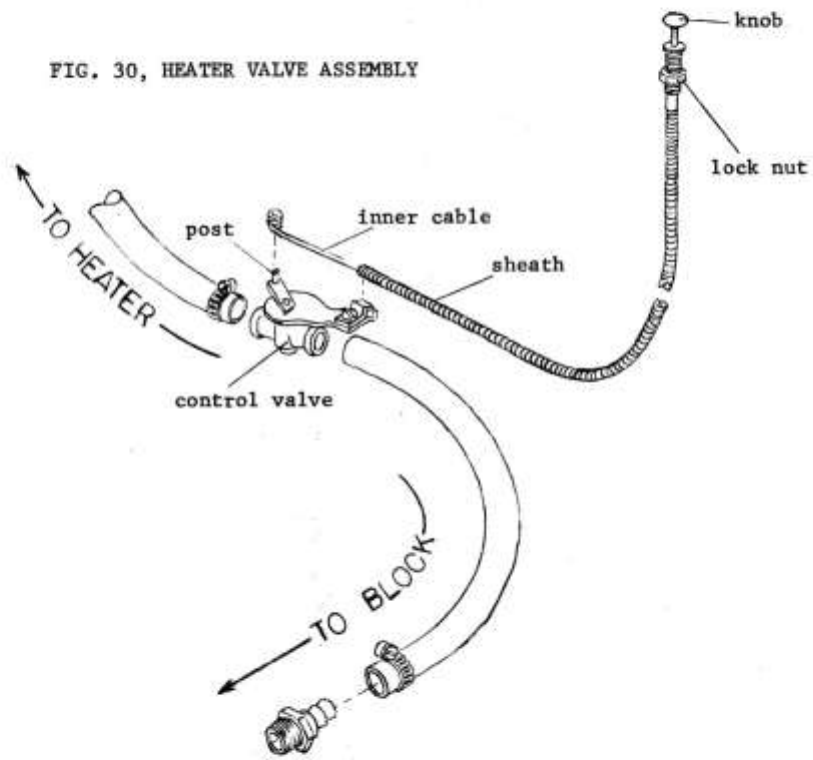

SECTION 10, ELECTRICAL SYSTEM

The electrical system in this vehicle is a 12-volt system utilizing standard automotive components, and with 2 batteries hooked in parallel.

PART 10-1, INSTRUMENT PANEL:

1. REMOVAL:

See Fig. 32

- 1.1 Remove the 4 screws (2 on top and 2 at base) holding the instrument panel and pull the panel out a little, just far enough so the connections in back of the panel can be reached.
- 1.2 Pull apart the two wiring harnesses.
- 1.3 Remove the speedometer cable from the speedometer head.
- 1.4 Disconnect the two heavy black wires to the ammeter.
- 1.5 Remove the instrument panel.

2. INSTALLATION:

See Fig. 32

Reverse the above removal procedure.

3. SENSOR LOCATIONS:

- 3.1 Fuel gauge sensor is located in the top center of the fuel tank. (See Fig. 3, SECTION 2)
- 3.2 Temperature gauge sensor is located on the right hand (passenger) side of the engine block, to the rear and under the manifold.
- 3.3 Oil pressure gauge sensor is located on the left hand (drivers side) side of the engine block, to the rear of the remote oil filter hose connection.
- 3.4 Differential temperature gauge sensor is located on the lower front of the differential housing, driver's side.

4. WIRING:

See Fig. 15-42

5. IGNITION SWITCH:

The ignition switch has three positions. With the key vertical, the switch is "off" and there is no current to the vehicle. Turning the key counter-clockwise from the "off" position engages the "accessory" position and supplies power to all accessories (lights, wipers, gauges, etc.) Turning the key clockwise from the "off" position engages the "on" position.

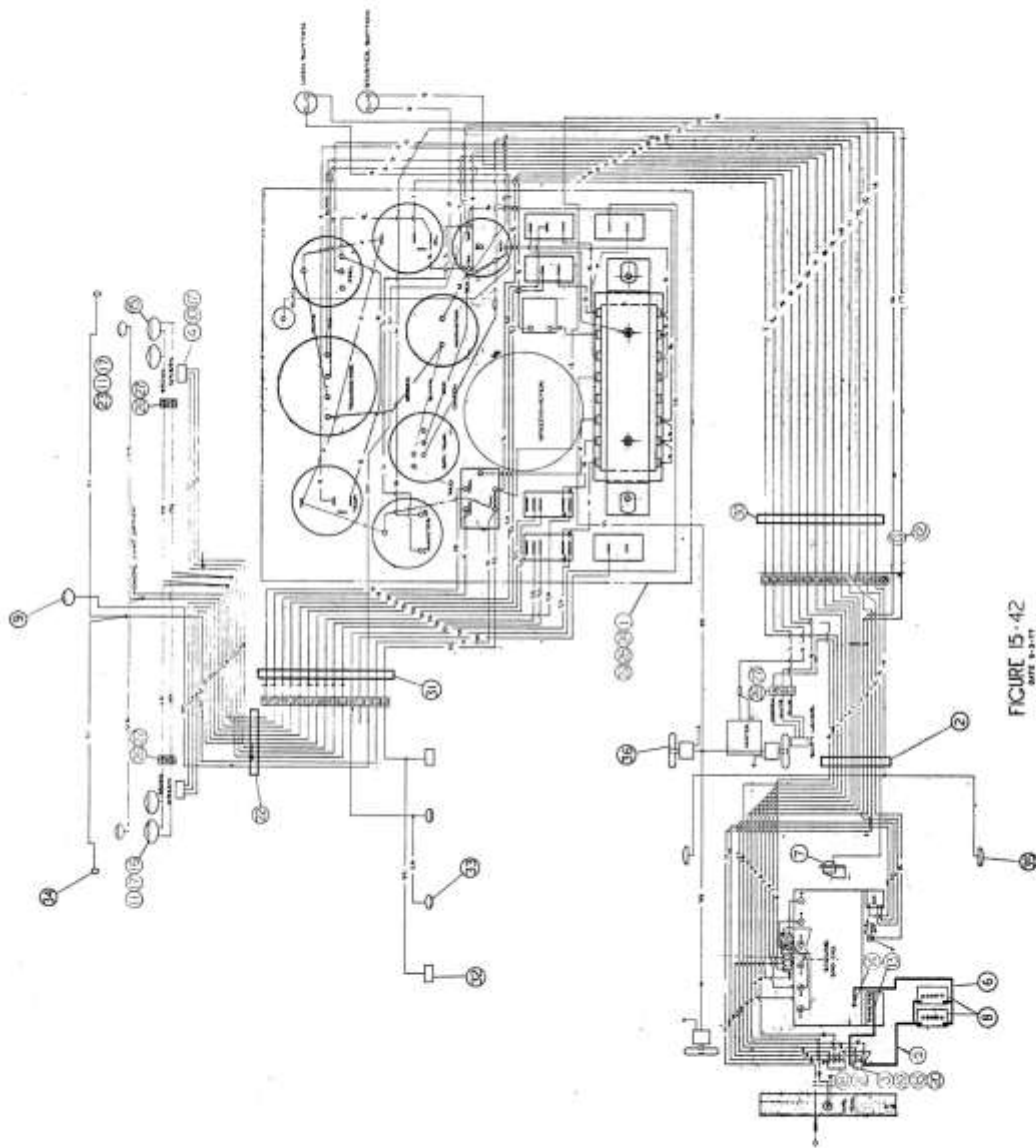
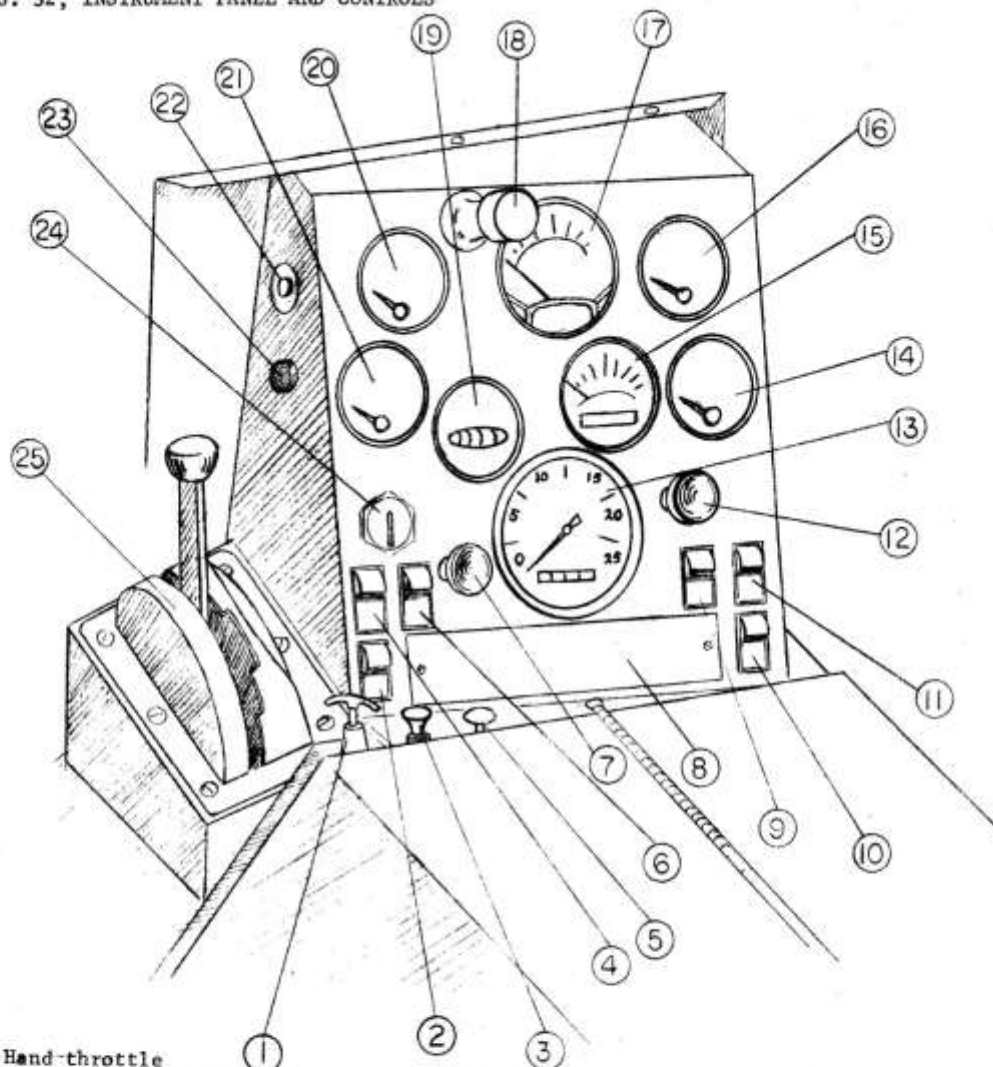

FIGURE 15-42
 ANS-10-101
 ELECTRONIC SYSTEM

FIG. 32, INSTRUMENT PANEL AND CONTROLS



- | | |
|--------------------------------------|------------------------------|
| 1. Hand-throttle | 14. Ammeter |
| 2. Back-up light switch | 15. Differential temp. gauge |
| 3. Choke | 16. Temp. gauge |
| 4. Emergency light switch (optional) | 17. Tachometer |
| 5. Heater valve control | 18. Light |
| 6. Interior light switch | 19. Hour meter |
| 7. Heater fan switch | 20. Fuel gauge |
| 8. Fuse box | 21. Oil pressure gauge |
| 9. Wiper switch L. H. | 22. Horn button |
| 10. Fog light switch (optional) | 23. Starter button |
| 11. Wiper switch R. H. | 24. Ignition switch |
| 12. Headlight switch | 25. Transmission control |
| 13. Speedometer | |

6. FUSE BLOCK:

See Fig. 32

To expose the fuse block, which is located on the lower portion of the instrument panel, remove the two screws holding the cover and remove the cover.

Fuses are as follows, going from left (driver's side) to right:

- 1 - 15 amp - emergency light, interior light
- 2 - 15 amp - heater fan
- 3 - 15 amp - back-up light
- 4 - 15 amp - fog light
- 5 - 10 amp - spare
- 6 - 30 amp - headlights, spotlight, clearance lights, tail lights.
- 7 - 10 amp - left hand wiper
- 8 - 10 amp - right hand wiper

7. PANEL LIGHT:

See Fig. 32

To replace a bulb (part #0115018): pull the hood off the light, push in on the bulb and turn it counter clockwise and remove. Align tabs on base of new bulb with slots in socket, shove bulb into socket, and while pushing in on bulb, turn it clockwise to seat.

8. ROCKER SWITCHES:

See. Fig. 32

These switches are held to the panel by spring clips. Removal of a switch is accomplished by prying under the chrome housing; switch will pop out. Installation is accomplished by pushing switch into the opening, it will simply snap in.

FOR INFORMATION ON IGNITION AND CHARGE SYSTEMS SEE FORD MANUAL IN FRONT OF THIS BOOKLET.

SECTION 11, SPEEDOMETER ASSEMBLY

See Figure 33

Concerning the speedometer assembly, the two things to remember are: (1) Don't overtighten anything, and (2) Install the cable in as gentle a curve as possible. Overtightening of the various fittings and too much bend in the cable are the most common causes of failure.

The speedometer assembly is assembled as shown in fig. 33. To get to the various parts of the assembly, you must remove the instrument panel as described in SECTION 10, Items 1 & 2, and, depending on whether the vehicle is tracked or untracked, crawl underneath the vehicle up to the speedometer housing (easiest when vehicle is tracked), or remove the cover plate located on the driver's side on the mid lower chassis (easiest when vehicle is untracked).

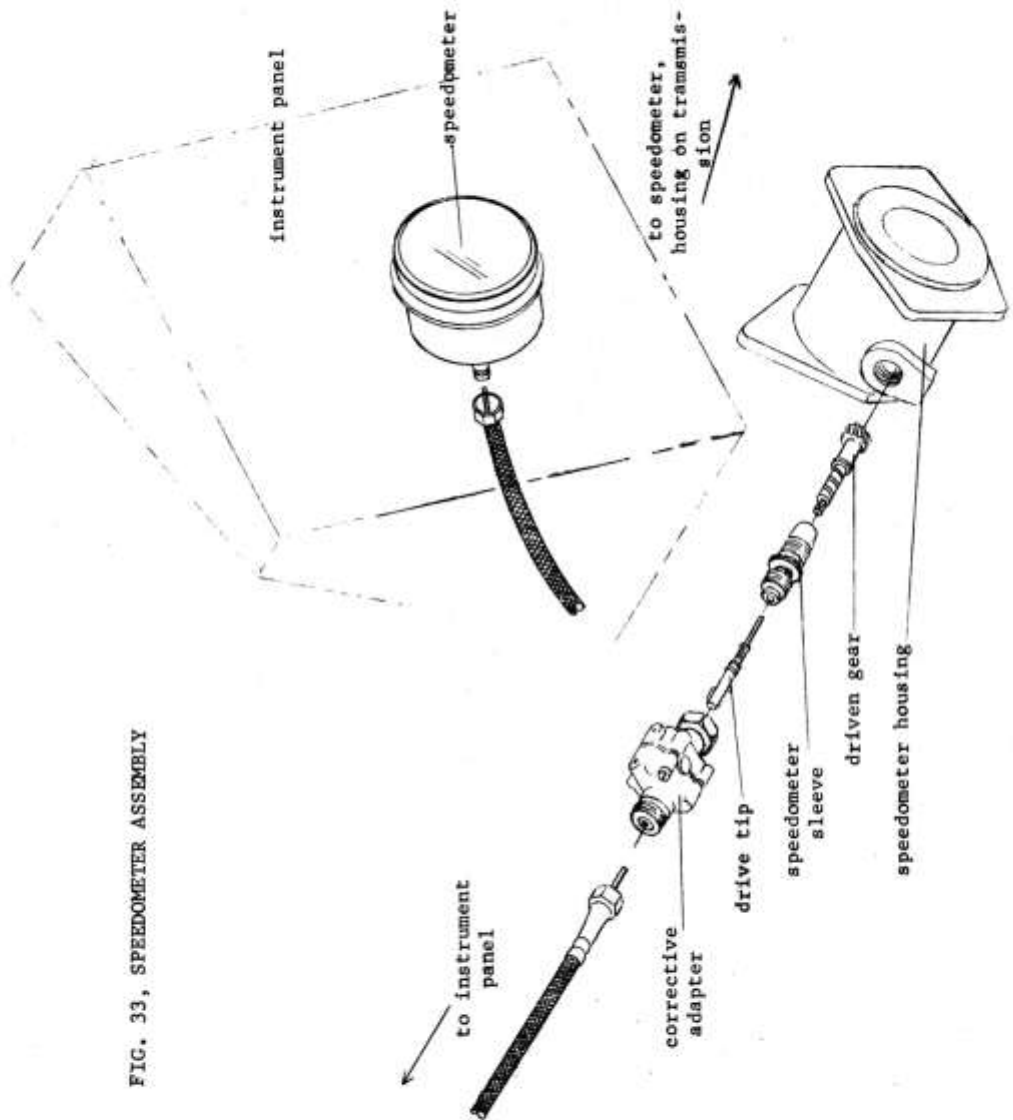

FIG. 33, SPEEDOMETER ASSEMBLY

SECTION 12, CHASSIS & CAB

PART 12-1, CHASSIS:

1. MOUNTING:

The chassis is mounted to the frame with 12 rubber mount assemblies, with 2 stops (one on each side of the chassis) over the middle frame cross-member to prevent the chassis from moving too far back or forward to damage the rubber mounts.

2. INSULATION:

The floor of the area enclosed by the cab (metal up front, 3/4" plywood back of the engine compartment) is covered with rubber insulation with aluminum tread plate over that. The rubber insulation is glued into place with 3M-4693 cement.

The front and sides of the area enclosed by the cab are insulated with sections of fiberglass, glued into place with 3M-4693 cement, and covered with aluminum sheet, pop-riveted into place. Over the aluminum is a layer of carpet, also glued with 3M-4693 cement, and edged with an aluminum strip around the top held into place with pop-rivets.

If removal of the aluminum sheet or edging becomes necessary, use a 1/8" drill to drill out the pop-rivets.

3. TREAD PLATE:

3.1 Removal:

Remove the countersunk flathead screws and tread plate will lift out.

3.2 Installation:

Reverse the above removal procedure.

4. SEATS:

4.1 Front seat:

4.1.1 Removal:

Remove the four nuts and washers underneath the seat holding it to its brackets and lift the seat out.

4.1.2 Installation:

Reverse the above removal procedure.

4.2 Rumble seat:

4.2.1 Removal:

Remove the four wing nuts underneath the seat holding it to the floor and lift the seat out.

4.2.2 Installation:

Reverse the above removal procedure.

4.3 Rear seat:

See Part 12-2, this Section.

5. ENGINE HOOD:

5.1 Removal:

Release both hood catches, then remove the two tie-down clips holding the hinge to the top of the engine compartment.

5.2 Installation:

Reverse the above removal procedure.

6. COVER PLATES:

There are 6 cover plates on various parts of the chassis, each giving access to important areas of the engine, transmission, or drive line.

6.1 Engine cover plates:

6.1.1 Location:

The engine cover plates are located forward of the engine hood on either side of the engine compartment. They provide access to radiator and heater hoses, alternator, part of the throttle linkage, motor belts and pulleys, part of the transmission control linkage, and the whole of the hand throttle, choke, and heater linkages.

6.1.2 Removal:

The cover plates are easily removed by removing the bolts around their perimeter.

6.1.3 Installation:

Reverse the above removal procedure.

6.2 Lower chassis cover plates:

6.2.1 Location:

There are three cover plates located on the lower chassis. One is located in front on the driver's side and gives access to the hydraulic system (optional). Another is located on the driver's side about the middle of the vehicle and provides access to the transmission, the third is located in front on the passenger side and provides access to the starter.

6.2.2 Removal:

The cover plates are easily removed by removing the bolts around their perimeter.

6.2.3 Installation:

Reverse the above removal procedure.

6.3 Rear access cover:

6.3.1 Location:

Located on the rear deck over the drive unit.

6.3.2 Removal:

Remove the bolts around its perimeter.

6.3.3 Installation:

Reverse the removal procedure.

7. DECK: (BED):

7.1 Removal:

7.1.1 To remove the deck (bed boards), the cab must first be removed. (see below PART 12-2). This is because the cab extending back from the engine compartment and forming the rear passenger space rests on part of the bed.

7.1.2 Now remove the tread plate behind the engine compartment (see Item 3 above). Then pull up the rubber insulation, thus exposing the bolts holding the bed boards in this area.

7.1.3 From this point removal of the bed is a matter of removing nuts and bolts, and lifting the boards out.

7.2 Installation:

Place deck boards into position and install bolts.

8. GAS TANK:

See Section 2

9. BATTERY BOX:

Batteries must be placed adjacent to each other on the driver's side in the battery box, leaving a gap on the passenger side of the battery hold-down to leave room for the cables.

PART 12-2, CAB:

1. INSULATION:

The cab is insulated largely with fiberglass, with foam and rubber

insulation making up the remainder. The insulation is glued down with 3M-4963.

The panels covering the insulation are either of masonite or aluminum and are held to the framework by screws except for a few small channel sections which are pop-riveted. Removal of pop-rivets is effected by the use of a 1/8" drill.

2. REPLACING HEADLIGHTS:

2.1 Removal:

- 2.1.1 Remove the 4 hex head bolts holding the headlight guard to the cab and remove the guard. Bolts are backed by weldnuts.
- 2.1.2 Remove the 4 screws around the chromed headlight bezel and remove the bezel.
- 2.1.3 Locate the light to be replaced and, with a pair of needle nosed pliers, disconnect the small coil spring located at the bottom of the light's housing.
- 2.1.4 Remove the two smaller screws (larger ones are for adjusting angle of beam and play no part in this procedure) from the housing and pull the light and housing from the cab. Unplug the light and slip it from the housing.

2.2 Installation:

Using correct sealed beam unit for replacement, reverse the above removal procedure.

3. DOOR HANDLES:

3.1 Removal:

- 3.1.1 Remove the hex head bolt in the center of the inside handle and pull the handle and spring out.
- 3.1.2 Remove the hex head bolt on the outside of the door next to the handle and remove the outside handle.

3.2 Installation:

Reverse the above removal procedure.

3.3 Maintenance:

Occasionally grease the shaft on the inside handle, also the spring.

4. WINDSHIELD WIPERS:

4.1 Wiper blades:

4.1.1 Removal:

Pull the small tab at the top of the wiper blade at the pivot where it attaches to the arm. Blade will fall off pivot shaft.

4.1.2 Installation:

Using proper replacement blade, snap onto pivot shaft on wiper arm.

4.2 Wiper arms:

4.2.1 Removal:

Arms are removed by pulling them off the splined shaft coming out of the motor. A screwdriver used as a prying instrument will help.

4.2.2 Installation:

Push the arm down onto the splined shaft coming out of the motor until you hear a "click" as the retaining spring snaps into place.

4.3 Wiper motors:

4.3.1 Removal:

First remove the arm as above, then remove the locknut and washer on the splined shaft housing. Remove the remaining screw and locknut and disconnect the leads, and pull the motor out from inside the cab.

4.3.2 Installation:

Reverse the above removal procedure.

5. CAB:

See Fig. 34 below:

5.1 Removal:

5.1.1 Remove the instrument panel as described in SECTION 10.

5.1.2 Remove the 9 bolts holding the cab to chassis. NOTE: In order to reach the two bolts on either side of the engine compartment, it is necessary to first remove the aluminum panel covering the insulation in front of the cab around the headlights.

5.1.3 With a suitable hoist, lift the cab from the chassis. Push the cab forward as it is being lifted to avoid tearing the heater out.

5.2 Installation:

Reverse the above removal procedure.

6. REAR SEAT:

6.1 Removal:

Lift seat back straight up to disengage hooks on seat back from tabs on cab.

Unsnap seat chains from cab then pick seat straight up to disengage lip from the crosspiece on the cab.

6.2 Installation:

Reverse the above removal procedure.

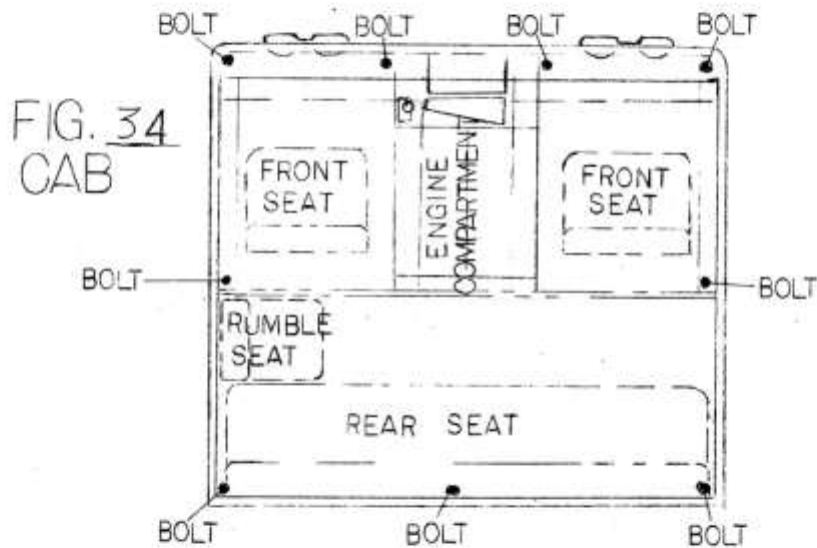

SECTION 13, TOOLS

1. STANDARD TOOLS:

	QUANTITY	ITEM
A.	1	Ratchet, $\frac{1}{2}$ " drive
B.	1	5" extension, $\frac{1}{2}$ " drive
C.	1	10" extension, $\frac{1}{2}$ " drive
D.	1	7/16" deep socket, $\frac{1}{2}$ " drive
E.	1	$\frac{3}{8}$ " socket, $\frac{1}{2}$ " drive
F.	1	$\frac{1}{2}$ " combination wrench
G.	1	Grease gun
H.	1	1 lb. ball peen hammer
I.	1	12" adjustable wrench
J.	1	8" gripping plier
K.	1	12" pry bar
L.	2	Track jacks
M.	1	Track spreader

2. TRACK REPAIR KIT:

A.	12	Belt lacing backing plates
B.	10	Regular backing plates
C.	2	Right hand cleats
D.	2	Left hand cleats
E.	4	Elastic stop nuts, 5/16 - 24NF
F.	4	hex head cap screws, 5/16 x 24 NF x 5LG
G.	21	Uni-torque lock nuts, 3/8 x 24NF x 1 1/4LG
H.	21	Hex head cap screws, 3/8 x 24NF x 1 1/4LG
I.	6	Belt lacings
J.	6	Hex head cap screws, 7/16 - 20 NF x 3/4LG
K.	2	1 $\frac{1}{2}$ " tire guides

L.	27	Hex head cap screws, 7/16 - 20NF x 1 1/4LG
M.	64	Uni-torque lock nuts, 7/16 - 20 NF
N.	31	Hex head cap screws, 7/16 x 20 NF x 1 1/2LG
O.	1	1411023-03 belt repair section
P.	1	1411023-02 belt repair section

SECTION 14
LUBRICATION CHART

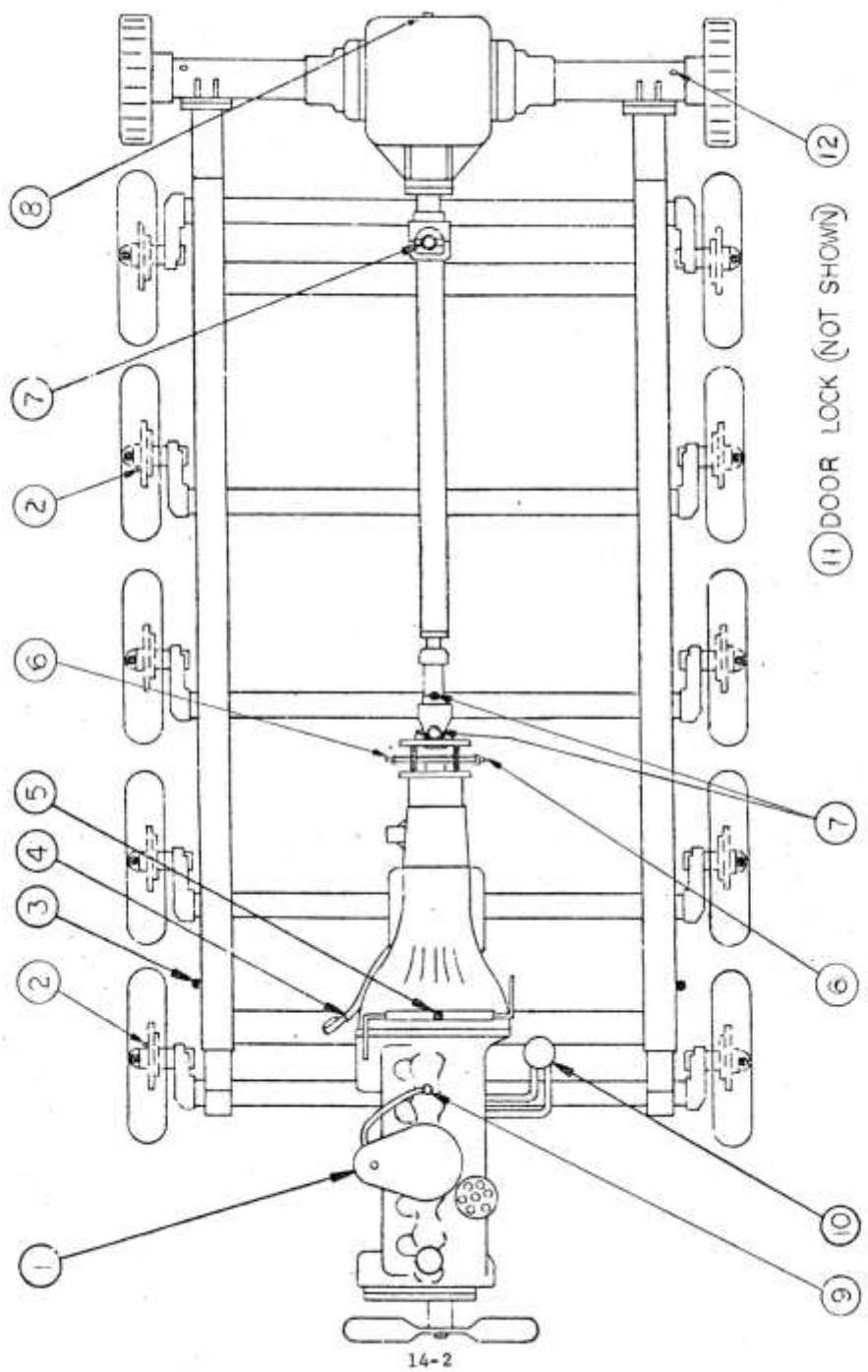

FIGURE 35 LUBRICATION CHART

LUBRICATION INSTRUCTIONS

See Fig. 35

LUBRICATION POINT	LUBRICANT	INTERVAL/INSTRUCTIONS
1. Oil bath air cleaner	Use same oil as in engine.	Drain and refill every engine oil change. Wash filter assembly in solvent every third or fourth oil change. Service air cleaner more frequently under severe dust conditions.
2. Wheel bearings	Use all temperature grease conforming to MIL-G-10924A or Conoco DN-600 grease.	Hubs are equipped with grease fittings. Flush grease through hubs frequently, depending on vehicle use and operating conditions. Flush bearings daily when operating in mud, silt, water.
3. Track adjusting cylinders.	Use all temperature grease conforming to MIL-G-10924A or Conoco DN-600 grease.	As required.
4. Automatic transmission	Use Ford Type F automatic transmission fluid or equivalent down to 0° F. From 0° F. to -65° F. use DN-600 fluid.	Check oil level frequently. This system is not filtered. If fluid is contaminated, drain and replace.
5. Throttle linkage	Use all temperature grease conforming to MIL-G-10924A or Conoco DN-600 grease.	As required.
6. Disc brake arm	All temperature grease conforming to MIL-G-10924A or Conoco DN-600 grease	Grease the brake arms every 50 hours

LUBRICATION INSTRUCTIONS

7. Drive shaft universal joints, sleeve yoke miscellaneous grease fittings.	All temperature grease conforming to MIL-G-10924A or Conoco DN-600 Grease.	Service grease fittings every 50 hours.																				
8. Steering differential.	From -65° F. to 0° F. Use Conoco DN-600 fluid. Above 0° use Dectol 116.	Drain and refill oil in steering differential after first 25 hours of operation. Thereafter, check oil level weekly and change oil every 150 hours of operation.																				
9. Engine	<p style="text-align: center;">MULTI-VISCOSITY OILS</p> <table border="1" style="width: 100%;"> <thead> <tr> <th style="text-align: center;">When Outside Temperature is Constantly</th> <th style="text-align: center;">Use SAE Viscosity Number</th> <th style="text-align: center;">When Outside Temperature is Constantly</th> <th style="text-align: center;">Use SAE Viscosity Number</th> </tr> </thead> <tbody> <tr> <td style="text-align: center;">-10°F. to +32°F.</td> <td style="text-align: center;">(*) 10W</td> <td style="text-align: center;">Below +32°F.</td> <td style="text-align: center;">(*) 8W/30</td> </tr> <tr> <td style="text-align: center;">+10°F. to +60°F.</td> <td style="text-align: center;">20W/30</td> <td style="text-align: center;">-10°F. to +60°F.</td> <td style="text-align: center;">10W/30</td> </tr> <tr> <td style="text-align: center;">+32°F. to +90°F.</td> <td style="text-align: center;">30</td> <td style="text-align: center;">-10°F. to +90°F. (or above)</td> <td style="text-align: center;">10W/40</td> </tr> <tr> <td style="text-align: center;">Above 90°F.</td> <td style="text-align: center;">40</td> <td style="text-align: center;">Above +10°F.</td> <td style="text-align: center;">20W/40</td> </tr> </tbody> </table> <p>(*) Where sustained high RPM operation is anticipated, use 20W20.</p>	When Outside Temperature is Constantly	Use SAE Viscosity Number	When Outside Temperature is Constantly	Use SAE Viscosity Number	-10°F. to +32°F.	(*) 10W	Below +32°F.	(*) 8W/30	+10°F. to +60°F.	20W/30	-10°F. to +60°F.	10W/30	+32°F. to +90°F.	30	-10°F. to +90°F. (or above)	10W/40	Above 90°F.	40	Above +10°F.	20W/40	Change oil supplied with engine after first 50 hours of operation. Thereafter, change oil every 100 hours of operation or at shorter intervals when vehicle is used at temperatures below 0 degrees F. Pour oil into PCV valve opening.
When Outside Temperature is Constantly	Use SAE Viscosity Number	When Outside Temperature is Constantly	Use SAE Viscosity Number																			
-10°F. to +32°F.	(*) 10W	Below +32°F.	(*) 8W/30																			
+10°F. to +60°F.	20W/30	-10°F. to +60°F.	10W/30																			
+32°F. to +90°F.	30	-10°F. to +90°F. (or above)	10W/40																			
Above 90°F.	40	Above +10°F.	20W/40																			
10. Oil filter	Use Fram PH - 8A oil filter.	Change filter with each oil change.																				
11. Door locks	All temperature grease conforming to MIL-G-10924A or Conoco DN-600 grease.	As required.																				
12. Drive axle bearings	All temperature grease conforming to MIL-G-10924A or Conoco DN-600 grease.	Service grease fitting every 25 hours under normal operation--3-4 pumps with grease gun.																				

SECTION 15, SPECIAL EQUIPMENT

PART 15-1, WINTERIZATION KIT:

See Fig. 36

1. ENGINE COOLANT HEATER:

Sediment and grease may affect the operation of the tank-type coolant heater. Flush coolant system thoroughly if needed. (see SECTION 9). Water and antifreeze should always be filled to proper level and hoses should be free of air pockets.

The tank-type coolant heater must be mounted low, 6" or more below cylinder head, as near vertical as possible. Angle should not exceed 45°.

2. BATTERY WARMER:

Battery cables and heating unit cords must be routed as far as possible from the heating unit to avoid possible heat damage.

3. OIL PAN HEATER:

When weather is extremely cold, oil heaters should be put into operation when engine oil is warm to avoid "coking" of the oil on the heating element.

4. WINTERIZATION KIT RECEPTACLE:

Mounted on the front lower chassis, driver's side. Requires special plug to fit. Correct plug is supplied with extension cord mounted behind front passenger seat.

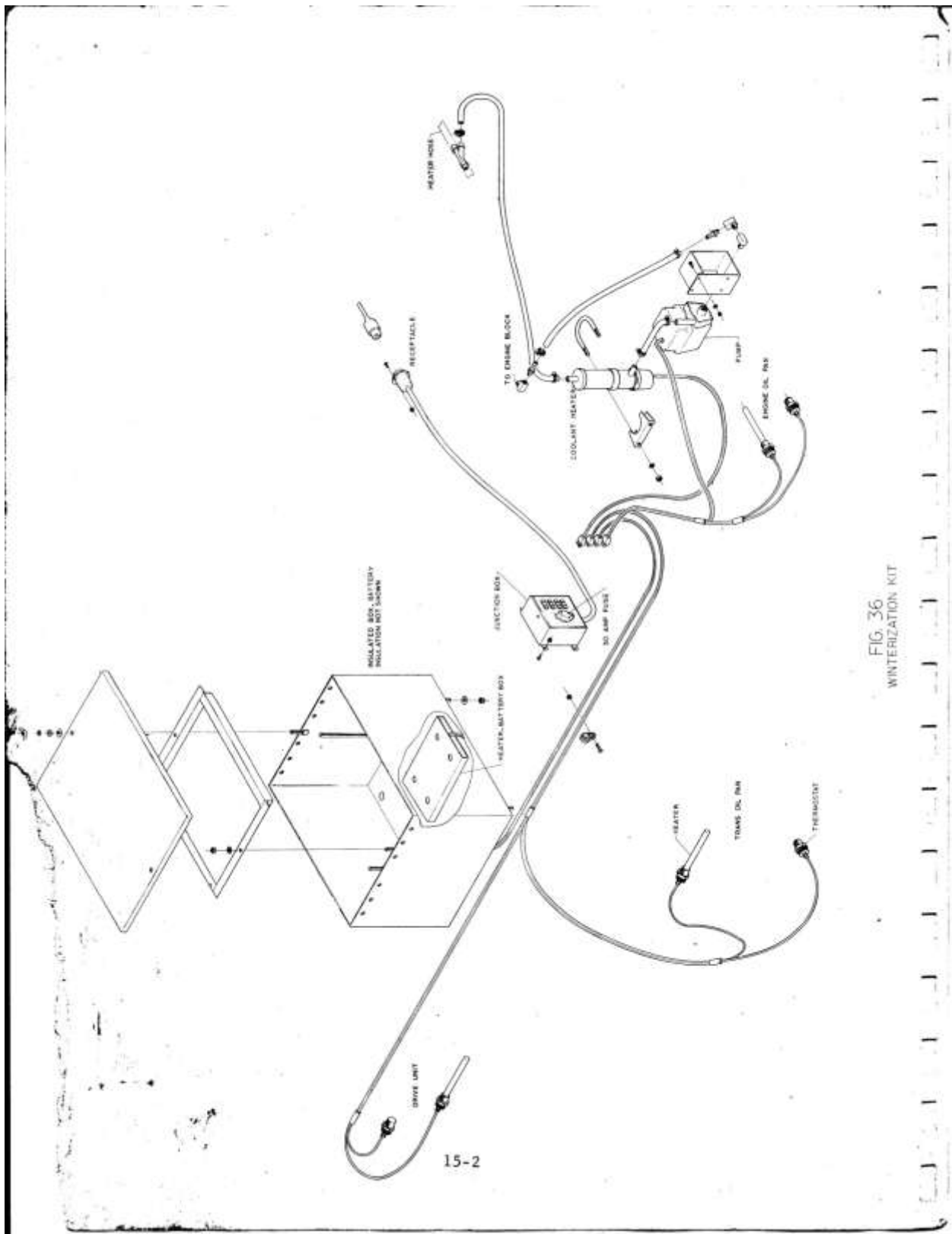

FIG. 36
WINTERIZATION KIT

